



Specification & Installation instruction



Feature:

- Clutch for manual adjustments.
- Maintenance free.
- Position indicator.
- Fail safe by *Enerdrive System*¹ (on model 060 & 080).
- Auxiliary switches (on model 020 & 080).

Old Number

TBT3000A	TT000
TBT3005A	TT005
TBT3021A	TT020
TBT3060A	TT060
TBT3065A	TT065
TBT3080A	TT080
RBT5000A	RT000
RBT5005A	RT005
RBT5021A	RT020
RBT5060A	RT060
RBT5065A	RT065
RBT5080A	RT080

Technical Data	TT000 TBT 3000A	TT005 TBT 3005A	TT020 TBT 3021A	TT060 TBT 3060A	TT065 TBT 3065A	TT080 TBT 3080A	RT000 RBT 5000A	RT005 RBT 5005A	RT020 RBT 5021A	RT060 RBT 5060A	RT065 RBT 5065A	RT080 RBT 5080A
Auxiliary switches	No	No	Yes(2)	No	No	Yes (2)	No	No	Yes(2)	No	No	Yes (2)
Feedback	No	Yes	No	No	Yes	No	No	Yes	No	No	Yes	No
Fail safe - Enerdrive	No			Yes			No			Yes		
Power consumption	8 VA			24 VA Peak, 8 VA			10 VA			24 VA Peak, 10 VA		
Control signal	3 wire / 2 position, 3 wire / 3 point floating			2 wire / 2 position, 4 wire / 3 point floating			3 wire / 2 position, 3 wire / 3 point floating			2 wire / 2 position, 4 wire / 3 point floating		
Weight	4.5 lbs. [2 kg]						7 lbs. [3.2 kg]					
Torque	180 in.lb. [20 Nm] at rated voltage						360 in.lb. [40 Nm] at rated voltage					
Running time through 90°	60 to 85 sec Torque dependant											
Power supply	22 to 26 VAC or 28 to 32 VDC											
Electrical connection	18 AWG [0.8 mm ²] minimum											
Inlet bushing	2 inlet bushing of 7/8 in [22.2 mm]											
Angle of rotation	0 to 90 degrees, mechanically adjustable with SLD (optional), (factory set with 90° stroke)											
Direction of rotation	Reversible, Clockwise (CW) or Counterclockwise (CCW) (factory set with CW direction)											
Ambient temperature	0°F to +122°F [-18° C to +50° C]											
Storage temperature	-22°F to +122°F [-30° C to +50° C]											
Relative Humidity	5 to 95 % non condensing.											

Warning: Do not press the clutch when actuator is powered

Dimensions

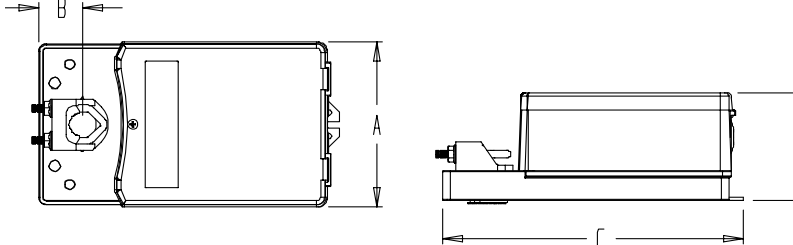

Dimension	Inches	Metric (mm)
A	5.20	132.1
B	1.33	33.8
C	9.13	231.9
D	3.55	90.2

Caution

We strongly recommend that all neptronic® products be wired to a separate transformer and that transformer shall service only neptronic® products. This precaution will prevent interference with, and/or possible damage to incompatible equipment.
When multiple actuators are wired on a single transformer, polarity must be observed. Long wiring runs create voltage drop which may affect the actuator performance.

¹ Enerdrive System U.S.A. Patent #5,278,454



Mechanical installation

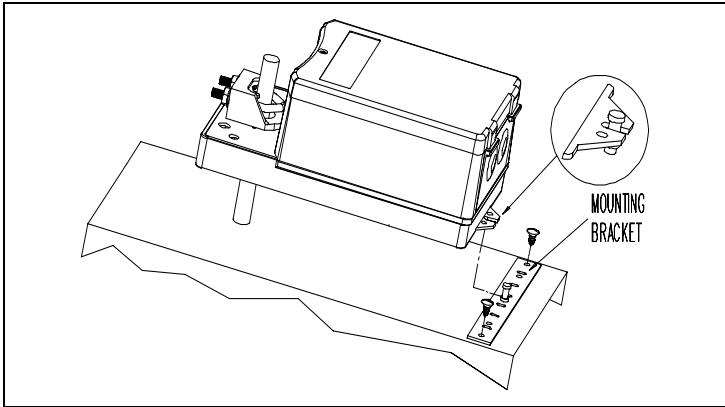

1. Manually close the damper blades and positioned the actuator at 0° or 90°.
2. Slide the actuator onto the shaft.
3. Tighten the nuts on the “U” bolt to the shaft with a 10mm wrench to a torque of 150 in.lb. [17 Nm].
4. Slide the mounting bracket under the actuator. Ensure free movement of the slot at the base of the actuator. The bracket pin must be placed in the mid distance of the slot.
5. Fix the bracket to the ductwork with #8 self-tapping screws.

Wiring Diagrams

Models TT000, 005 & 020
 RT000, 005 & 020

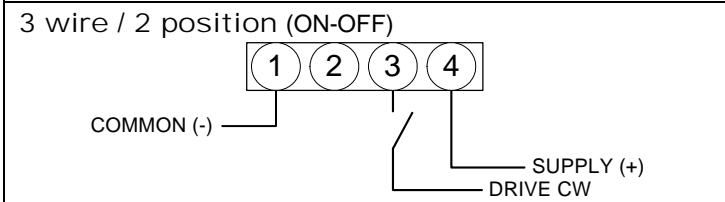

Models TT060, 065 & 080
 RT060, 065 & 080

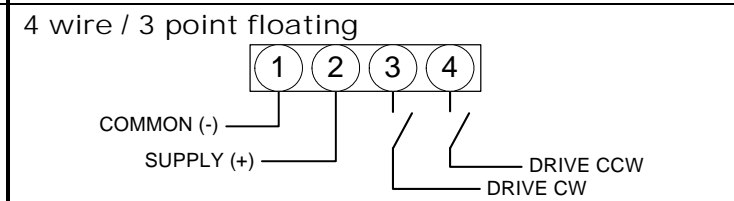
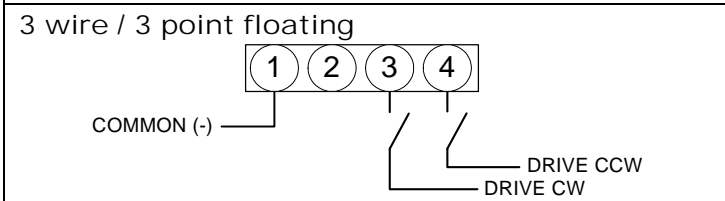
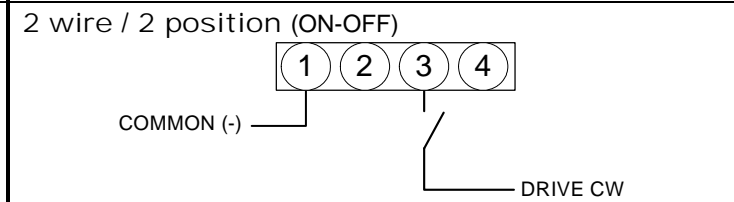

PC Board

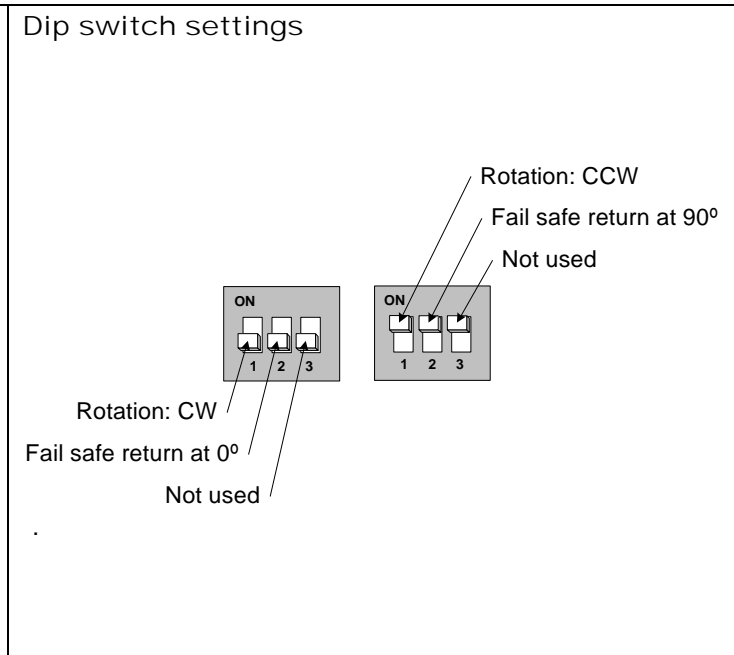
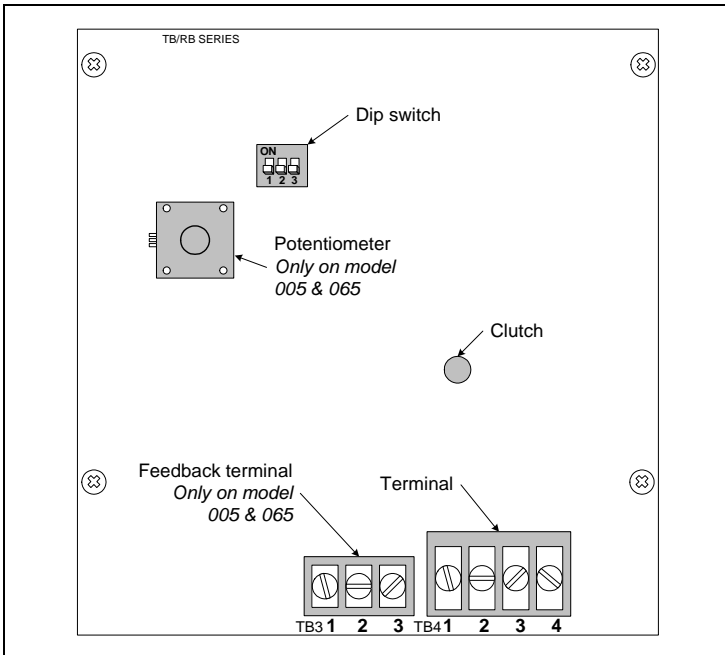

Stroke adjustment

To adjust the stroke, use the stroke limiting device (SLD). (not included)