



Sensor without display



Sensors with LCD display



Red = alarm for fault

Green = in operation

### Features

- ATEX and IEC Ex certificates for electrical Ex protection
- ATEX metrical test & SIL2 safety functions 4 – 20 mA, RS485 and relay
- Type “Ex d” with flame-proof enclosure
- Continuous monitoring
- Self-monitoring system
- Easy calibration
- Calibration service by exchanging the sensor head
- Reverse polarity protection
- Overload protection
- LCD display with status LEDs (optional)
- Alarm and fault signal relay (optional)
- Can be opened during operation (sealed)

### Technical Data

<b>Power supply</b>	16 – 28Vdc, 20 – 29Vac
<b>Power consumption (at 24Vdc)</b>	90 mA, max. 130 mA
<b>Control unit</b>	Microprocessor with 12 bit converter resolution
<b>Digital filter</b>	Averaging in order to increase the EMC immunity
<b>Visual indications</b>	2 LEDs for operation, alarm and communication
<b>Analog output signal (active)</b>	Proportional, overload and short-circuit proof, load ≤ 500 Ω 4 – 20 mA = measuring range 3,2 < 4 mA = underrange > 20 – 21.6 mA = overrange 2.5 mA = service mode 2 mA = fault Low > 21.8 mA = fault High
<b>Serial interface</b>	Serial data bus
<b>Fault relay (optional)</b>	Max. 30Vac/dc, 1 A
<b>Alarm relay (optional)</b>	Max. 30Vac/dc, 1 A
<b>LCD (optional)</b>	2 x 16 characters, 3 status LEDs, 4 menu operating elements
<b>Sensor data</b>	
<b>Gas type</b>	Toxic gases & oxygen
<b>Sensor element</b>	<b>Electrochemical    Infrared</b>
<b>Measuring range</b>	See Ordering Information    0 – 100 % LEL
<b>Response time</b>	$t_{90} \leq$ depending on gas type $t_{90} \leq 30$ sec
<b>Accuracy</b>	Depending on gas type    ± 1 % below 25% of measuring range
<b>Repeatability</b>	Depending on gas type    ± 2 % of measuring range

### Design Features

Microprocessor based gas detector with 4 – 20 mA / RS485 Modbus output signal, alarm and fault relays (all SIL2 certified) for monitoring the ambient air to detect oxygen and toxic gases and vapors by means of an electrochemical sensor element (el.ch.) or an infrared sensor element.

The calibration of detectors without LCD display is carried out via the calibration device Cal ATEX or the PC software PC-ATEX.

Detectors with LCD display have an integrated calibration routine that is started from the outside by a permanent magnet without opening the housing.

In case of an **alarm or a fault** the backlight of detectors with LCD display changes from **green to red**.

The gas sensor is sealed and thus the housing in zone 1 can be opened during operation at any time (Ex demb[ib]).

### Application

The detector is used in industrial areas like oil/gas industry, biogas plants, petrochemical industry, power plants etc. in Ex-Zone 1.

The detector is also suitable for commercial areas like gas transfer stations etc.

With the 4 – 20 mA / RS485-ModBus output signal the detector is suitable for connection to the AP gas leak alarm units, as well as to any other controllers or automation devices.

Optionally, the detector is also available with LCD display and relay output.

### Ordering Codes (see p. 2)



# Explosion Proof ATEX - Detector for Toxic Gases and Oxygen in Zone 1, sealed

## ATEX 1 SIL 2

Feb. 16

<b>Stabilization time</b>	300 sec.	900 sec.
<b>Warm-up time</b>	Measuring mode after 120 sec.	Measuring mode after 60 sec.

### Environmental Conditions

<b>Humidity</b>	20 to 90% r.H (non-condensing)
<b>Operating temperature</b>	-25 °C to 55 °C (reduced measuring operation up to +65 °C)
<b>Storage temperature</b>	-5 °C to +30 °C
<b>Pressure range</b>	800 to 1200 mbar (80 to 120 kPa)
<b>Air velocity</b>	< 6 m/sec.

### Physical Characteristics

<b>Case / colour</b>	Die-cast aluminium / light grey RAL 7032
<b>Dimensions (D x H)</b>	95 x 82 mm
<b>Weight</b>	Ca. 1.3 kg
<b>Protection class</b>	IP 54
<b>Mounting</b>	Wall mounting (sensor head downwards)
<b>Cable entry</b>	1 x ¾ in.
<b>Wire connection</b>	Spring-type terminal, 0.08 to 2.5 mm <sup>2</sup> AWG 28 - 12
<b>Wire length</b>	Max. load 500 Ω (= wire resistance + controller input resistance)

**ATEX / IEC Ex approval** CE 0158 II2G Ex d IIC T4 (pending)

**EC-type examination certificate** Electrical Ex protection: Ex demb[ib] EN60079-0, -1, -11, -18 (zone 1)  
 Metrological approval: (pending)  
 EN 60079-29-1 for Ex gases  
 Functional safety (SIL2)  
 EN 50402  
 EN 61508-1, -2, -3  
 EN 50271

**WARRANTY** 1 year on material and workmanship (without the sensor)

### Ordering Codes

Detector	Gas Type		Sensor Type	Measuring range
ATEX1 CO 500	Carbon monoxide	CO	El. chem.	0-500 ppm
ATEX1 NH3 100	Ammonia	NH <sub>3</sub>	El. chem.	0-100 ppm
ATEX1 NH3 200	Ammonia	NH <sub>3</sub>	El. chem.	0-200 ppm
ATEX1 NH3 1000	Ammonia	NH <sub>3</sub>	El. chem.	0-1000 ppm
ATEX1 NO 100	Nitrogen monoxide	NO	El. chem.	0-100 ppm
ATEX1 NO2 20	Nitrogen dioxide	NO <sub>2</sub>	El. chem.	0-20 ppm
ATEX1 C2H4 200	Ethylene	C <sub>2</sub> H <sub>4</sub>	El. chem.	0-200 ppm
ATEX1 Cl2 5	Chlorine	Cl <sub>2</sub>	El. chem.	0-5 ppm
ATEX1 Cl2 20	Chlorine	Cl <sub>2</sub>	El. chem.	0-20 ppm
ATEX1 SO2 20	Sulphur dioxide	SO <sub>2</sub>	El. chem.	0-20 ppm
ATEX1 H2S 50	Hydrogen sulphide	H <sub>2</sub> S	El. chem.	0-50 ppm
ATEX1 O2 25	Oxygen	O <sub>2</sub>	El. chem.	0-25 vol %
ATEX1 O2 21	Oxygen	O <sub>2</sub>	El. chem.	0-21 vol %
ATEX1 CO2 5	Carbon dioxide	CO <sub>2</sub>	Infrared	0-5 vol %

### Options:

<b>Relay-set</b>	2 Relay outputs
<b>LCD Display</b>	Display with menu status
<b>Relay-set + LCD Display</b>	Display and Relay Pack

### Electrical connection

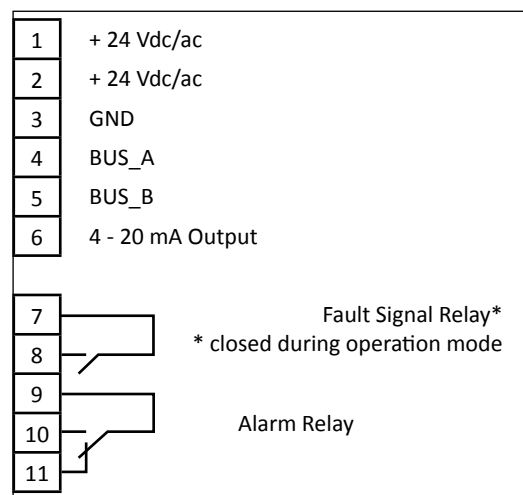

We cannot be held responsible errors in the manual/datasheet and reserve the right to correct any errors and to make product improvements, which may affect the accuracy of the manual/datasheet, without prior notice.