



Nitrogen Dioxide Detector Analogue + Relay Output + RS485 NO2

May.10



Display-version



NO2 Wall



NO2 Duct



Features

- Digital measurement values
- Comfort calibration with selective access release
- Continuous monitoring
- Low zero point drift
- Poisoning stable
- Long life sensor
- Modular plug-in technology
- Easy maintenance/calibration
- Reverse polarity protected
- Overload protected and short circuit proof
- 4-20mA or 2-10Vdc output signal
- 2 relays output adjustable switching thresholds
- Manual addressing for RS485 mode. eg. Modbus

Technical Data

Gas	Nitrogen dioxide
Detection principle	Electrochemical, diffusion
Accuracy	0,1ppm
Repeatability	<2% of reading
Long term output drift	<2% signal loss/month
Response time	t90 <60 sec.
Storage time	Max 3 months
Mounting height	0,2 metres above floor
Output signal	(0)4-20mA, load 500ohm
Selectable	(0)2-10Vdc, load 50kohm
Starting point	0/20%
Relay 1	30Vac/dc, 0,5A, pot.free SPDT
Relay 2	Dito SPNO/SPNC
Consumption	30mA, max 0,8VA
Serial Interface	
Transceiver	RS485/19200 Baud/9600 at Mod
Protocol	Depending in version
Power supply	18-28Vac/dc, reverse polarity prot. for 2-wire mode only Vdc
Power consumption	
Analogue	22mA, max (0,6VA)
Bus mode	12mA, max.(0,3VA)
Expected lifetime	2 years, normal operating envirom.
Humidity range	15-90% rH non-condensing
Operating range	10 up to +45C
Rating	IP65 Protection Class
Pressure range	Atmospheric +/-15%

Application

For detection of nitrogen dioxide within a wide range of industrial and commercial applications such as underground garages, engine repair shops, tunnels, engine test benches, shelters and loading bays with diesel-engined vehicles.

Due to the standard output signal and the RS485 interface the NO2 transmitter is compatible to the Gas Controller GCM and GCD as well as to any other electronic control or automation system

Ordering Codes

Manual calibration via potentiometer

NO2 010VC 0-10/0-20ppm

Calibration and addressing by service Tool

NO2 020VCT 0-10/0-20ppm

/MOD	Protocol for Modbus
/CUST	Protocol for customers specifications
/GCD	Protocol for GCD-series
/REL NO2	Relay pack see rear side
/DUCT	Duct Mounting
/LCD	Two lines, 16 characters each
/CAL 2	Calibration Kit for Tox-transmitters
/HEAT	Temp.controlled heating element 3C +/-2C0,3VA
/BUZZ	Internal warning summer 85dB
/STAIN	Enclosure of stainless steel
/SERV	Service Tool with Keyapad and LCD-display
/AIN	4-20mA analogue input
GAS 17	Calibration gas 17 liter
REG	Pressure regulator flow adjusted to 0,5 lit/min.

Warning devices See special datasheet

Warning signs See special datasheet

Physical Characteristics

Enclosure	Polycarbonate
Flammability	UL94: V2 Halogenfree
Enclosure colour	RAL 7032 (light grey)
Dimensions	94x130x57mm
Weight	Approx. 0,5kg
Installation	Wall mounting
Cable entry	Standard 1xM20
Wire connection	Screw type terminal min. 0,25mm2 and max 2,5mm2
Wire distance	Current signal cirka 500m Voltage signal cirka 200m
Guidelines	EMV-Directive 89/336/EWG, CE EM-Directive 2004/108/EWG, CE

Relay Package

The two relays are activated in dependence of the gas concentration.

If the gas concentration exceeds the adjusted alarm threshold, the corresponding relay switches on.

If the gas concentration falls below the threshold minus hysteresis, the relay switches off again.

The contact function for relay 2, NC (normally closed) or NO (normally open), can be selected via jumper NO/NC.

See fig.1 and 3.

Relay one is equipped with a change-over contact.

Via the Modbus interface the two alarm thresholds and the hysteresis are freely adjustable at the PC within the measuring range.

The procedure can be read from the user manual Modbus Software.

The following parameters are factory set.

Alarm threshold 1 = Relay 1: 2 ppm

Alarm threshold 1 = Relay 2: 5 ppm

Switching hysteresis: 1 ppm

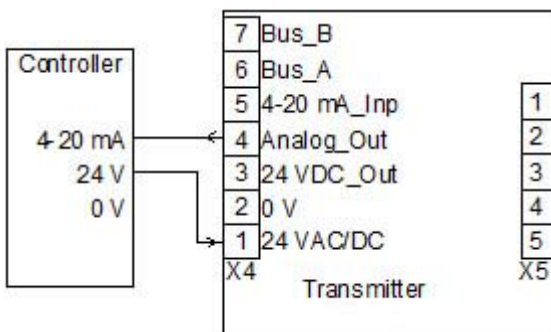

Two-wire connection, 4-20mA output signal without option

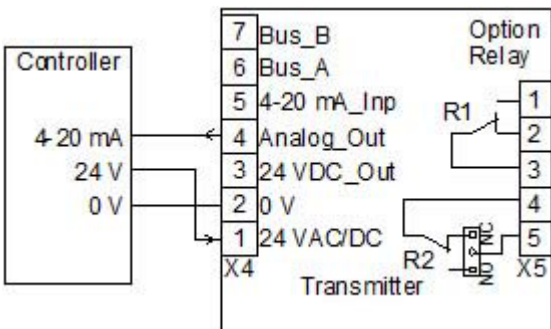

Three-wire connection, Vdc or 0-20mA output signal
Relay output, LCD display, Heating

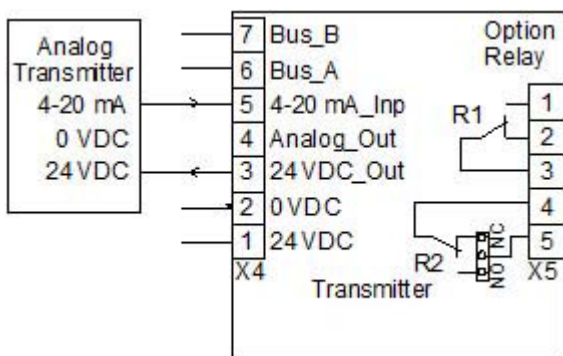

Connection analogue transmitter

Two- or three wire connection, depending on transmitter type

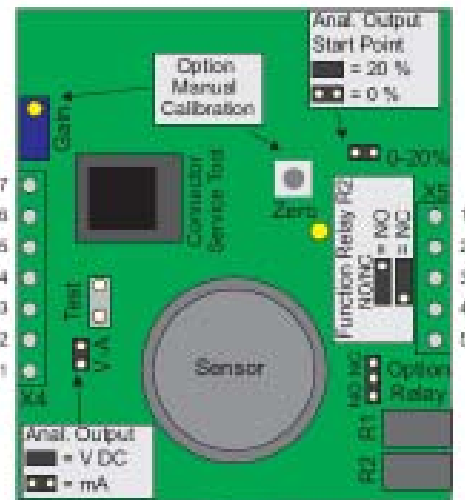

GCD-05 Bus mode

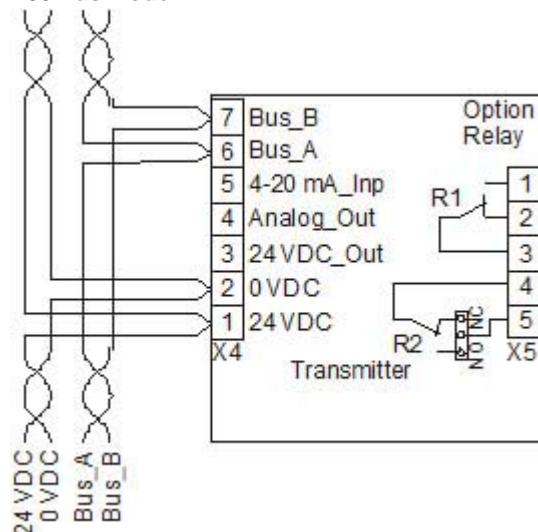

Connection field bus and tension