



Ammonia Gas Detector

15 ppm accuracy
-40...+10 degree

ENH3

April.10



ENH3 display



ENH3 Wall



ENH3 Duct



Features

- The superior solution to semiconductor
- Selective
- Stable within a wide temperature range
- Comfortable calibration with selective access release
- 4-20mA or 2-10Vdc output signal selectable
- Digital measurement value processing incl. temperature compensation
- Reacts quickly on ammonia leakage
- Integrated heating element temperature controlled for down to -40 degree (option)

Technical Data

Gas	Ammonia (NH ₃)
Detection principle	Electrochemical, diffusion
Response time	t90 <120 sec., t50 <20 sec.
Accuracy	<15 ppm
Repeatability	< 5% of reading
Zero-point	0 ppm +/-15ppm
Long term outdrift	< 10% signal loss/6 months
Sensor coverage	Approx.100m ²
Storage time	3 months
Mounting height	Under the ceiling
Output signal	
(0)4-20mA	Load < 500ohm overload and short circuit proofed
(0)2-10Vdc	Load < 50kohm overload and short circuit proofed
Starting point 0/20%	Proportional
Relay 1	30Vac/dc, 0,5A, pot.free SPDT
Relay 2	Dito SPNO/SPNC
Wiring distance	Current signal cirka 500m Voltage signal cirka 200m
Cable entry	1 x M20
Serial interface	RS485 19200 Baud
Power supply	18-28Vac/dc reverse polarity prot.
Power consumption	22mA, max (0,6VA) without option
Analogue input	4-20mA, only RS485 mode 24Vdc
Expected lifetime	>18 months,normal operating
Humidity range	15-90%rH non-condensing
Operating range	Continuous -40 up to +10C
Rating	IP65 Protection Class
Pressure range	Atmospheric +/-15%
These products meet the CE-approval	

Application

For detection leakages in refrigeration plants with ammonia as refrigerant and also within a wide range of commercial and industrial applications.

Due to the analogue signal and the RS-485 serial interface the NH₃ transmitter is compatible to monitoring units by AP, as well as any others controllers or automation systems.

Ordering Codes

Wall Mounting

Manual calibration and adresssing

NH3 300VC	0- 300ppm	(0)4-20mA/ (0)2-10Vdc	sel.
NH3 1000VC	0-1000ppm	(0)4-20mA/ (0)2-10Vdc	sel.
NH3 2000VC	0-2000ppm	(0)4-20mA/ (0)2-10Vdc	sel.

Calibration and adresssing by service tool

NH3 300VCT	0- 300ppm	(0)4-20mA/ (0)2-10Vdc	sel.
NH3 1000VCT	0-1000ppm	(0)4-20mA/ (0)2-10Vdc	sel.
NH3 2000VCT	0-2000ppm	(0)4-20mA/ (0)2-10Vdc	sel.

/MOD	Protocol for Modbus
/CUST	Protocol for customers specifications
/GCD	Protocol for GCD-series
/REL 1-3	Relay pack see rear side
/DUCT	Duct Mounting
/LCD	Two lines, 16 characters each
CAL 2	Calibration Kit for Tox-transmitters
/HEAT	Temp.controlled heating element 3C +/-2C0,3VA
/BUZZ	Internal warning summer 85dB
/STAIN	Enclosure of stainless steel
/SERV	Service Tool with Keyapad and LCD-display
/AIN	4-20mA analogue input
GAS 17	Calibration gas 17 liter
REG	Pressure regulator flow adjusted to 0,5 lit/min.
Warning devices	See special datasheet
Warning signs	See special datasheet



Relay Package

With the NH3 relay package two potential-free contacts are available for the connection to external devices.

The switching thresholds of these relays are selectable via potentiometer in the range of 10 - 90% of NH3 concentration.

The hysteresis is programmable via jumpers.

Additionally the relay mode, open-circuit or closed circuit, is selectable.

The status of the two relays is displayed via LED

Add analogue input 4-20mA is not possible.

For standard RS 485 fixed thresholds - please specify when ordering.

For Modbus RS 485 thresholds with software changeable

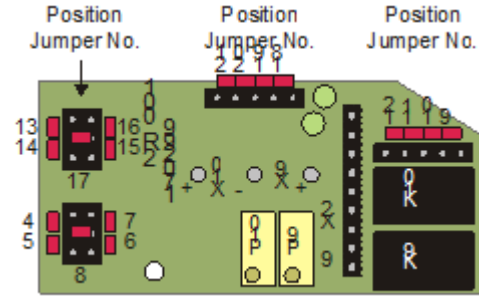

Relay Package

Threshold standard as stand alone

Relay	Range	Threshold
Relay 4NH	0-300 ppm	100 resp 200 ppm
Relay 5NH	0-1000ppm	200 resp 800 ppm
Relay 6NH	0-2000ppm	300 resp 1800 ppm

Connecting Diagram

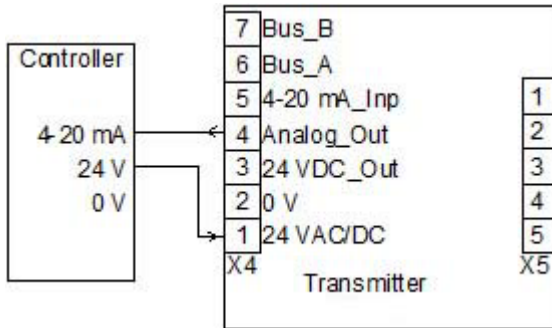

Two-wire connection by 4-20mA without option

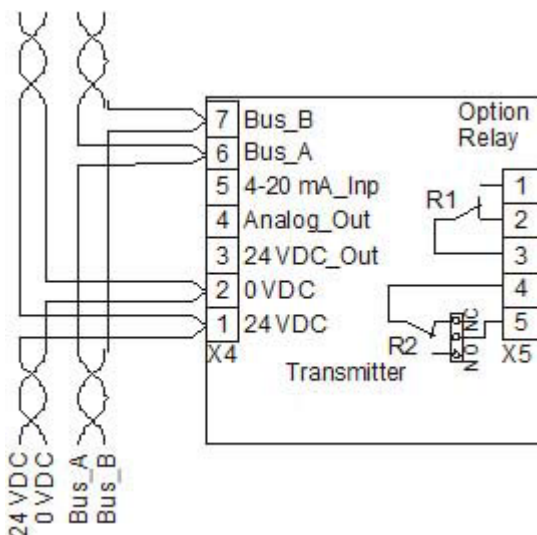

Connection field bus and tension GCD Gas Controller

Cross sensitivity

Gas	Concentration	Reaction
Carbon Monoxide CO	100 ppm	95 ppm
Alcohols	1000 ppm	yes
Hydrogen H2	3000 ppm	3000 ppm
Hydrogen Chloride	10 ppm	0 ppm
Sulphur Dioxide	20 ppm	5 ppm
Hydrogen Sulphide	20 ppm	40 ppm
Phosphates	300 ppm	0 ppm
Nitrogen Dioxide	10 ppm	0 ppm
Chlorine CL2	5 ppm	0 ppm
Carbon Dioxide	0.5 %	0 ppm
Amines	---	yes
Arsines	0,2 ppm	0 ppm

The table does not claim to be complete.

Other gases, too can have influence on the sensitivity.

The mentioned cross sensitivity data are only reference values valid for new sensors.

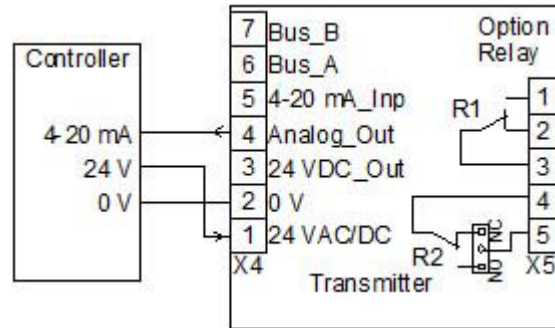

Three-wire connection

- Vdc outputsignal
- 0-20mA output signal
- Relay output
- LCD display
- Heating

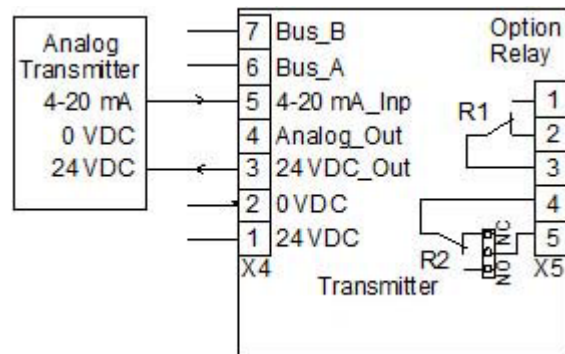

Connection analog transmitter Field bus

Two or three wire connection, depending on transmitter type.