



Oxygen 0-25% Gas Detector

LO2

Oct.10



LO2

Features

- Continuous monitoring
- Low zero point drift

- Poisoning stable
- Long life sensor

- Easy maintenance/calibration

- Reverse polarity protected

- Overload protected

- 4-20mA loop-powered or 2-10Vdc output signal

Technical Data

Gas	Oxygen
Detection principle	Electrochemical, diffusion
Stability & resolution	+/- 0,1% vol.
Long term sensitivity	<4%/12 (% reading/month).
Response time	t90 <15 sec.
Storage time	6 months
Mounting height	1,2-1,8 metres above floor
Output signal	
4-20mA	load < 500ohm overload and short circuit proofed
2-10Vdc	load < 50kohm overload and short circuit proofed
Power supply	18-28Vdc (reverse polarity prot.)
Power consumption	22mA, max (0,6VA)
Expected lifetime	>2 years, normal operating environment
Humidity range	
Continuous	15-90% rH non-condensing
Operating range	
Continuous	-10 up to +50C
Rating	IP44 Protection Class
Pressure range	Atmospheric +/-10%

Application

For detection of oxygen in rooms where changes of the oxygen concentration are possible, such as laboratories and food production etc.

Due to the analogue signal 4-20mA and 2-10Vdc the O2 transmitter is compatible to any electronic analogue control, DDC/PLC control or automation system.

Ordering Codes

Wall Mounting

LO2 025VC 0-25% vol. 4-20mA/2-10Vdc

- Stain** Enclosure of stainless steel
- Tool** Tool for opening holes in stainless steel enclosure
- /GCD** Protocol for CDA-series
- GAS 17** Calibration gas 17 liter
- REG** Pressure regulator flow adjusted to 0,5 lit/min.
- Warning devices** See special datasheet
- Warning signs** See special datasheet

Technical Data continue

Physical Characteristics

Enclosure	GW Plast 75 GWT
Flammability	UL94: VO Halogenfree
Enclosure colour	RAL 7032 (light grey)
Dimensions	80 x 40mm
Weight	Approx. 0,2kg
Installation	Wall mounting
Cable entry	Standard 3 pieces
Wire connection	Screw type terminal min. 0,25mm ² and max 2,5mm ² Max. loop resistor 500ohm (= wire resistor + controller input resistor)
Guidelines	EMC-Directive 89/336/EWG, CE EMC-Directive 2004/108/EWG, CE

Maintenance

At commissioning and at periodic intervals determined by the person responsible for the gas detection system (**recommendation every year**).

After exchange of the sensor

If in case of operational or climatic influences the sensitivity of the sensor **falls below 30 %** in operation, calibration will not be possible any more.

Then the sensor has to be changed.

Exchange of sensor element

Sensor should always be installed without power applied:

- Unplug basic PCB EC-S carefully from the terminal blocks on the base.
- Unplug old sensor element from the PCB EC-S.
- Plug in sensor element into the PCB EC-S.
- Plug in the PCB EC-S into terminal block carefully.
- Calibrate

Connecting Diagram

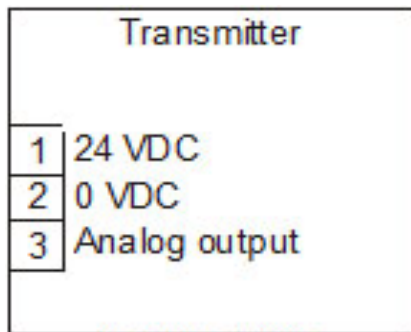

Terminal 2 is only for 2-10Vdc signal = 3-wire
4-20mA two-wire loop powered

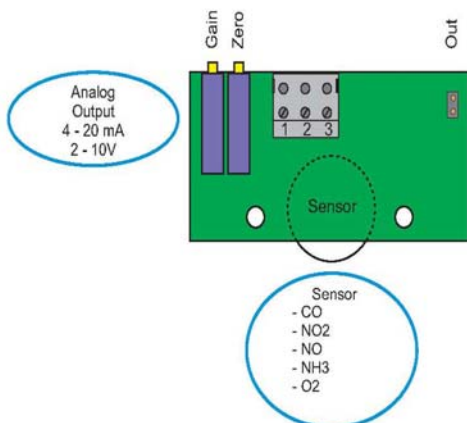

Calibration

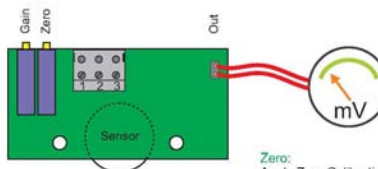

Zero:
Apply Zero Calibration Gas
U Out = 40 mV (Adjust with Potentiometer Zero)

Gain:
Apply Calibration Gas
U Out = $160 \text{ mV} \times \frac{\text{Calibration Gas Concentration (ppm)}}{\text{Measuring range (ppm)}} + 40 \text{ mV}$
(Adjust with Potentiometer Gain)