

- 1 Intended Use**
- 2 Functional Description**
  - 2.1 Control Mode
  - 2.2 Sensor
- 3 Installation**
  - 3.1 Mounting instructions
  - 3.2 Installation
- 4 Electrical Connection**
  - 4.1 Instruction
- 5 Commissioning**
  - 5.1 Adressing,only for GCD-05\_Bus Mode
  - 5.2 Check of the Analogue Output Signal
  - 5.3 Option Relay Output
- 6 Inspection and Service**
  - 6.1 Inspection
  - 6.3 Exchange of sensor element
- 7 Troubleshooting**
  - 7.1 Analogue Mode
  - 7.2 GCD-05\_Bus Mode
- 8 Technical Data**
- 9 Figures**
- 11 Notes and General Information**
  - 11.1 Intended product application
  - 11.2 Installers' responsibilities
  - 11.3 Maintenance
  - 11.4 Limited warranty



## **Infrared Carbon Dioxide Transmitter**

### **1 Intended Use**

The CO<sub>2</sub> transmitter with digital processing of the measuring values and temperature compensation is used for the monitoring of leakages in refrigeration plants with carbon dioxide as refrigerant agent.

The measuring ranges 2000 ppm and 5000 ppm are provided for the indoor air quality control.

The intended sites are all areas being directly connected to the public low voltage supply, e.g. residential, commercial and industrial ranges as well as small enterprises (according to EN50 082).

The CO<sub>2</sub> transmitter must not be used in potentially explosive atmospheres.

### **2 Functional Description**

#### **2.1 Control Mode**

In addition to the analog output the transmitter is equipped with a serial interface RS-485 for the connection to the GCD-05 system.

##### **Analog mode:**

The analog output can be selected as current signal with (0)4-20 mA or as voltage signal (0)2-10 V.

In the 4-20 mA mode and without any supplementary options, the CDK only works in the 3-wire technique.

##### **DGC-05\_Bus mode:**

The transmitter can be connected to the GCD-05 system via the RS-485 interface. In this mode there is an analog input for the connection of an additional 4-20 mA transmitter.

The two measuring values are transmitted via the RS-485 interface to the gas controller.

The cable topology for the RS-485 bus can be taken from the "Guidelines for wiring and commissioning of the GCD-05 hardware".

The two control modes are available in parallel.

#### **2.2 Sensor**

The integrated sensor is based on the principle of the infrared absorption of gases and accomplishes highest requirements concerning accuracy, reliability and economy.

The sensor technology uses the individual absorption spectrum of the carbon dioxide gas and appoints its exact concentration through its accurate, quantitative analysis.

The infrared principle nearly eliminates the cross-sensitivity to other gases.

An integrated evaluation electronic system reliably compensates all drift and temperature influences and therefore a genuine measurement result is guaranteed.

The sensor is factory-calibrated for a period of 10 years.

### 3 Installation

**Note:**

Avoid any force (e.g. by thumb) on the sensor element during operation or installation.

This could destroy the sensor element.

Electronics can be destroyed by static electricity.

Therefore, do not touch the equipment without a wrist strap connected to ground or without standing on a conductive floor.

#### 1.1 Mounting Instructions

When choosing the mounting site please pay attention to the following:

- The specific weight of carbon dioxide CO<sub>2</sub> is higher than that of air (factor 1,529).

Recommended mounting height for leak detection is **0.6 m (2 feet) to 0.8 m** (2.5 feet) above floor.

For the **indoor air quality control** the recommended mounting height is **1.2 to 1.5 m** (4 to 5 feet).

- Choose mounting location of the sensor according to the local regulations.
- Consider the ventilation conditions! Do not mount the transmitter in the centre of the airflow (air passages, suction holes).
- Mount the transmitter at a location with minimum vibration and minimum variation in temperature (avoid direct sunlight).
- Avoid locations where water, oil etc. may influence proper operation and where mechanical damage might be possible.
- Provide adequate space around the sensor for maintenance and calibration work.

#### Duct mounting

- Mount only in a straight section of duct with minimum air vortex. Keep a minimum distance of 1 m (3,5 feet) from any curve or obstacle.
- Mount only in a duct system with a maximum air velocity of 10 m/s (2000 ft/min) or less.
- Mounting must be performed so that the probe openings are in line with the airflow.

#### 3.2 Installation

- Open the cover.
- Fix the housing to the wall through the holes at the 4 corners using the enclosed screws/ wall anchors (sensor down).
- Replace the cover.

### 1 Electrical Connection

Consider static electricity! See 3. Mounting

- Installation of the electrical wiring should only be executed by a trained specialist according to the connection diagram, without any power applied to conductors and according to the corresponding regulations!
- Avoid any influence of external interference by using shielded cables for the signal line, but do not connect the shield.
- Recommended cable for analog mode: J-Y(St)Y 2x2x0,8 LG (20 AWG), max. resistance 73 Ω/km (20.8 Ω/1000 ft).
- Required cable for RS-485 mode: J-Y(St)Y 2x2x0,8 LG (20 AWG), max. res. 73 Ω/km (20.8 Ω/1000 ft)
- It is important to ensure that the wire shields or any bare wires do not short the mounted PCB.

#### 1.1 Wiring Connection

- Open the cover. Unplug basic PCB carefully from terminal blocks X4 and X5. Pay attention to the cable to the sensor.
- Insert the cable and connect cable leads to terminal blocks. See fig. 1 and 2.
- Replug the PCB in the terminal blocks X4, X5 with care. Replace the cover.

## 5 Commissioning

Consider commissioning instructions at any exchange of the sensor element as well.

Only trained technicians should perform the following:

The filter at the gas inlet is part of the IP65 protection and must not be removed.

- Check mounting location.
- Select output signal form: Current or voltage, and starting point 0 or 20%. See fig.3 and 4.
- Check power voltage.
- Check PCB SM03 for correct mounting at X4 and X5.
- Addressing of the transmitter in the GCD-05\_Bus mode.
- The transmitter is already factory-calibrated for 10 years.  
Therefore calibration is not required at commissioning.

**Note:**

The sensor is ready for use after a running-in period of 1 minute. During that period the zero-point signal is transmitted.

### 5.1 Addressing, only for GCD-05\_Bus mode

In the GCD-05\_Bus mode each transmitter gets its communication address.

In the standard version with the communication connector X12, addressing is done by means of the GCD-05 Service Tool or by the GCD-05 Configuration and Calibration Software.

See user manual of the Service Tool or of the Configuration and Calibration Software.

In the manual addressing version which can be identified by the address switch being equipped, there is a maximum of 60 addresses to be selected. See fig. 3.

The jumper is responsible to define the address group and the switch to define the address according to the following table.

Switch position	Jumper pos. 01 =address	Jumper pos. 02 =address	Jumper pos. 03 =address	Jumper pos. 04 =address
0	inactive	inactive	inactive	inactive
1	01	16	31	46
2	02	17	32	47
3	03	18	33	48
4	04	19	34	49
5	05	20	35	50
6	06	21	36	51
7	07	22	37	52
8	08	23	38	53
9	09	24	39	54
A	10	25	40	55
B	11	26	41	56
C	12	27	42	57
D	13	28	43	58
E	14	29	44	59
F	15	30	45	60

### 5.2 Check of the Analog Output Signal

The output signal can be checked at the test pins (see fig. 3) in dependence of the detected gas by using the following formula.

#### Signal start 2 V / 4 mA

$$\text{Control voltage (mV)} = \frac{160 \text{ (mV)} \times \text{test gas concentration CO}_2 \text{ (ppm)}}{\text{measuring range CO}_2 \text{ (ppm)}} + 40 \text{ (mV)}.$$

#### Signal start 0 V / 0 mA

$$\text{Control voltage (mV)} = \frac{200 \text{ (mV)} \times \text{test gas concentration CO}_2 \text{ (ppm)}}{\text{measuring range CO}_2 \text{ (ppm)}}$$

#### Example:

Measuring range	50.000 ppm (5 Vol %)
Test gas concentration	20.000 ppm (2 Vol %)
Control voltage: Signal start 2 V / 4 mA	104 mV
Control voltage: Signal start 0 V / 0 mA	80 mV

#### Signal start: 2 V / 4 mA

$$\frac{160 \text{ (mV)} \times 20.000 \text{ (ppm)}}{50.000 \text{ ppm}} + 40 \text{ (mV)} = 104 \text{ mV}$$

#### Signal start: 0 V / 0 mA

$$\frac{200 \text{ (mV)} \times 20.000 \text{ (ppm)}}{50.000 \text{ (ppm)}} = 80 \text{ mV}$$

### 5.3 Option Relay Output

The two relays are activated in dependence of the gas concentration.

If the gas concentration exceeds the adjusted alarm threshold, the corresponding relay switches on.

If the gas concentration falls below the threshold minus hysteresis, the relay switches off again.

The contact function for relay 2, NC (normally closed) or NO (normally open), can be selected via the jumper NO/NC.

See fig 1 and 3. Relay 1 is equipped with a change-over contact.

Via the ModBus interface the two alarm thresholds and the hysteresis are freely adjustable at the PC within the measuring range.

The procedure can be read from the user manual "ModBus Software".

The following parameters are factory-set for the measuring range **5 Vol%**.

Alarm threshold 1 = Relay 1:	15000 ppm
Alarm threshold 2 = Relay 2:	30000 ppm
Switching hysteresis:	500 ppm

## 6 Inspection and Service

### 6.1 Inspections

Inspection, service and calibration of the transmitters should be done by trained technicians and executed at regular intervals.

We therefore recommend concluding a service contract with AP or one of their authorized partners.

### 6.2 Exchange of Sensor Element

The sensor is always replaced together with the PCB.  
Consider static electricity! See point 3.

- Unplug basic PCB SM03 carefully from the bottom part.
- Unscrew the sensor.
- Exchange the PCB sensor unit.
- Fix new sensor at the two screws, taking care not to over-tighten.
- Replug the PCB SM03 in the terminal blocks X4, X5 carefully.
- Define the output signal function in analog mode, address in DGC05\_Bus mode. See section 5.

## 7 Troubleshooting

### 7.1 Analog Mode

Trouble	Cause	Solution
Output signal < 3 mA / 1,5 V and/or control voltage < 30 mV only for starting signal 2V/4 mA	Jumper 0-20 % not set	Check jumper position
	Power voltage not applied	Measure tension at X4: Two-wire: Pin 1 (+) and 4 (-) Three-wire: Pin 1 (+) and 2 (-)
	PCB AT03 not plugged in correctly at X4 and X5	Replug PCB correctly
	Wire break	Check the wiring
Output signal > 22 mA /220 mV	Short-circuit	Check the wiring
No reaction of the output signal in spite of gas concentration	Power voltage not applied	Measure tension at X4
	Signal (Pin 4) not wired correctly	Check the wiring

### 7.2 GCD-05\_Bus Mode

Trouble	Cause	Solution
Yellow LED not shining	Power voltage not applied	Measure tension at X4:Pin 1 (+) and 2 (-)
	PCB not plugged in correctly at X4/X5	Replug PCB correctly
	Wire break	Check wiring
Yellow LED not flashing	No communication at the transmitter	Transmitter not addressed, check bus wiring incl. topology and termination Voltage < 16 V



## 8 Technical Data

### General sensor performances

Gas type	Carbon dioxide (CO <sub>2</sub> )
Sensor element	Two-beam infrared (NDIR)
Measuring range	0 – 2000 ppm to 0 - 100 Vol%
Temperature range	- 10 °C to + 40 °C (14°F to 104°F)
Pressure range	800 -1100 hPa
Humidity	0 – 95 % RH non condensing
Storage temperature range	0 °C to 50 °C (32 °F to 122 °F)
Storage time	Max. 6 months
Mounting height for leak detection	<b>0.6 to 0.8 m (2 to 2.5 ft.)</b>
Mounting height for indoor air quality control	<b>1.2 to 1.6 m (4 to 5 ft.)</b>
Stability & resolution	< 2 % of full scale
Repeatability	< 2 % of full scale
Resolution	0,01 Vol.-%
Long-term zero-point drift	< 2% signal loss/year
Long-term output signal drift	< 2% signal loss/year

### Electrical

Power supply	18 - 28 VDC/AC, reverse polarity protected
Power consumption (without options)	45 mA, max. (1.1 VA)

### Output signal

Analog output signal	(0) 4 – 20 mA, load ≤ 500 Ω,
Selectable: Current / tension	(0) 2 - 10 V; load > 50 k Ω
Starting point 0 / 20 %	proportional, overload and short-circuit proof

### Serial interface

Transceiver	RS-485 / 19200 Baud (9600 ModBus)
Protocol, dep. on version	GCD-05 or ModBus

### Physical

Enclosure <sup>1</sup>	Polycarbonate
Flammability	UL 94 V2 Halogenfree
Enclosure colour	RAL 7032 (light gray)
Dimensions	(W x H x D) 94 x 130 x 57 mm
Weight	0.5 kg (1 lbs.)
Protection class	IP 65
Mounting	Wall mounting
Cable entry	Standard 1 x M 20
Wire connection	Screw-type terminal min. 0.25 to max. 2.5 mm <sup>2</sup> 24 to 14 AWG
Wire distance	Current signal ca. 500 m (1500 ft.) Voltage signal ca. 200 m (600 ft.)

### Guidelines

EMC Directive 2004 / 108 / EEC  
CE

### Warranty

1 year on material (without sensor)



#### Options

##### Relay output 0-5 Vol%

Alarm relay 1 (switching threshold 15000 ppm)	30 VAC/DC 0,5 A, potential-free, SPDT
Alarm relay 2 (switching threshold 30000 ppm)	30 VAC/DC 0,5 A, potential-free SPNO/SPNC
Power consumption	30 mA, (max. 0,8 VA)

##### Warning buzzer

Acoustic pressure	85 dB (distance 300 mm) (1 ft.)
Frequency	3,5 kHz
Power consumption	30 mA, (max. 0,8 VA)

##### LCD display

LCD	Two lines, 16 characters each, not illuminated
Power consumption	10 mA, (max. 0,3 VA)

##### Heating

Temperature controlled	3 °C ±2°C (37.5 °F ± 3.6 °F)
Ambient temperature	- 30 °C (- 22°F)
Power consumption	0,3 A; 7,5 VA

##### Analog input

Only for RS-485 mode	4 – 20 mA overload and short-circuit proof, input resistance 200 Ω
Power supply for external transmitter	24 VDC max. 50 mA



### 9. Figures Analogue Mode

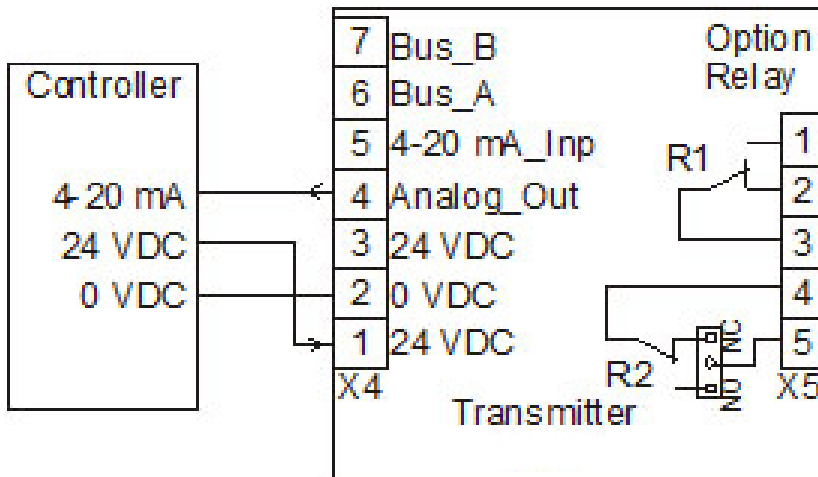

### GCD-05\_Bus Mode

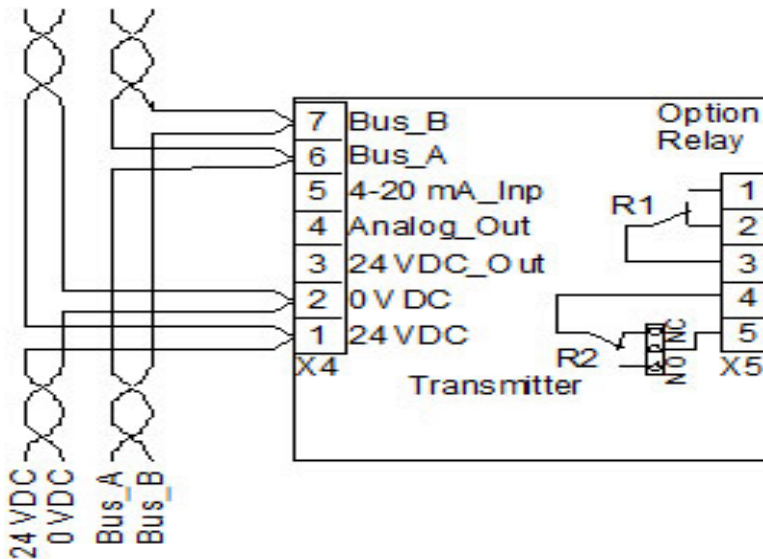

Connection field bus and tension

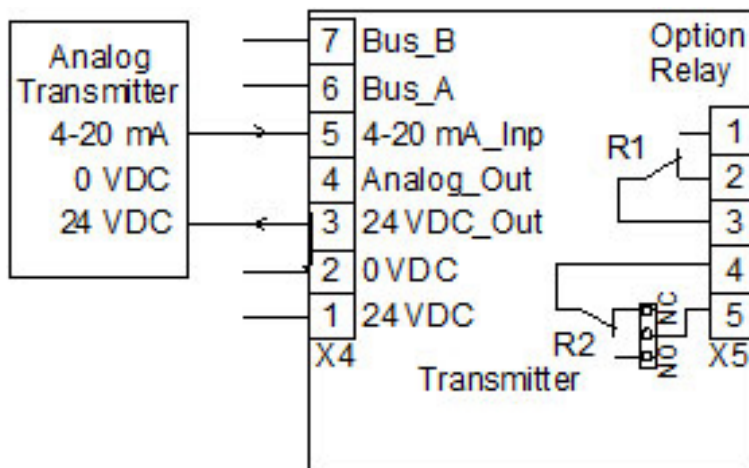

Connection analogue transmitter

Two or three-wire connection depending on transmitter type

Fig.3

PCB SM03

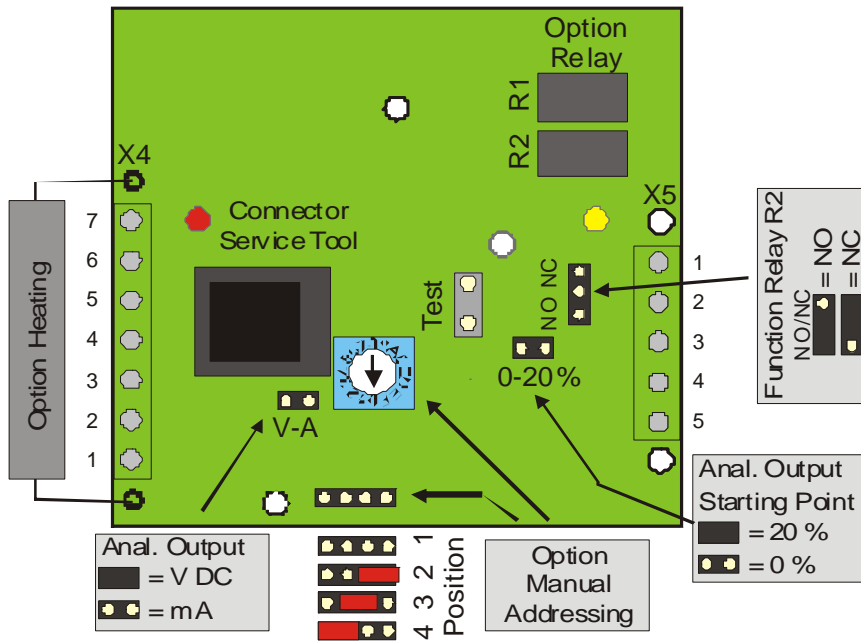

Terminal Block

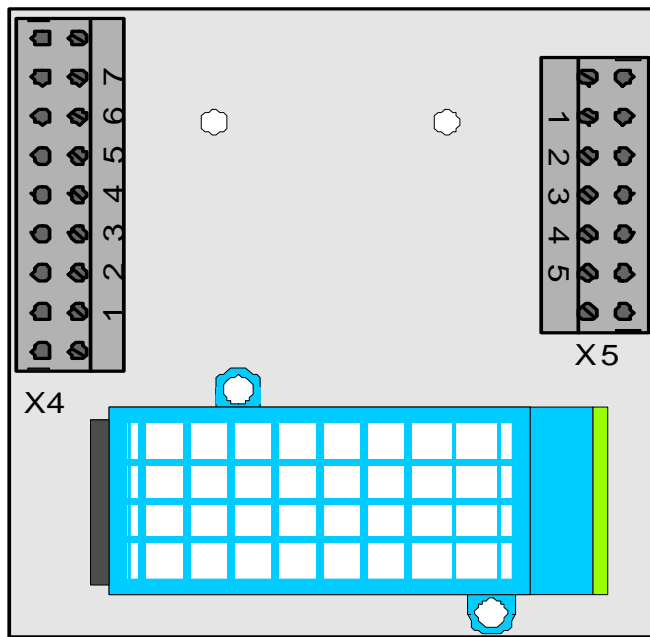

#### Selection analog output signal

Fig. 4

Jumper 0- 20 %	Jumper V-A	Output signal
Not set	Not set	0 – 20 mA
Set	Not set	4 – 20 mA
Not set	Set	0 – 10 V
Set	Set	2 – 10 V



## **10 Notes and General Information**

It is important to read this user manual thoroughly and clearly in order to understand the information and instructions.

The AP transmitters must be used within product specification capabilities.

The appropriate operating and maintenance instructions and recommendations must be followed.

Due to on-going product development, AP reserves the right to change specifications without notice.

The information contained herein is based upon data considered to be accurate.

However, no guarantee is expressed or implied regarding the accuracy of this data.

### **10.1 Intended product application**

The CDK transmitters are designed and manufactured for control applications and air quality compliance in commercial buildings and manufacturing plants.

### **10.2 Installers' responsibilities**

It is the installer's responsibility to ensure that all AP transmitters are installed in compliance with all national and local codes and OSHA requirements.

Installation should be implemented only by technicians familiar with proper installation techniques and with codes, standards and proper safety procedures for control installations and the latest edition of the National Electrical Code (ANSI/NFPA70).

It is also essential to follow strictly all instructions as provided in the user manual.

### **10.3 Maintenance**

It is recommended to check the AP transmitter regularly.

Due to regular maintenance any performance deviations may easily be corrected.

Re-calibration and part replacement in the field may be implemented by a qualified technician and with the appropriate tools.

Alternatively, the easily removable plug-in transmitter card with the sensor may be returned for service to AP

### **10.4 Limited warranty**

AP warrants the transmitters for a period of one (1) year from the date of shipment against defects in material or workmanship.

Should any evidence of defects in material or workmanship occur during the warranty period, AP will repair or replace the product at their own discretion, without charge.

This warranty does not apply to units that have been altered, had attempted repair, or been subject to abuse, accidental or otherwise.

The warranty also does not apply to units in which the sensor element has been overexposed or gas poisoned.

The above warranty is in lieu of all other express warranties, obligations or liabilities.

This warranty applies only to the AP transmitter.

AP shall not be liable for any incidental or consequential damages arising out of or related to the use of the AP transmitters.