



# Chlorine Gas Detector

## CI2

Oct.10



Display-version



CI2 Wall



CI2 Duct



### Features

- Digital measurement value processing incl. temperature compensation
- Comfort calibration with selective access release
- Continuous monitoring
- Low output drift
- Poisoning stable
- Long life sensor
- Modular plug-in technology
- Easy maintenance/calibration
- Reverse polarity protected
- Overload protected and short circuit proof
- 4-20mA or 2-10Vdc output signal
- 2 relays output adjustable switching thresholds
- Manual addressing for RS485 mode. eg. Modbus

### Application

For detection of chlorine within a wide range of industrial and commercial applications like waterworks, sewage plants, swimming pools etc..

Due to the standard output signal and the RS485 interface the O2 transmitter is compatible to the Gas Controller GCM and GCD as well s to any other electronic control or automation system

### Ordering Codes

Wall Mounting	Manual calibration via potentiometer
<b>CI2 002VC</b>	0-2ppm 24Vac/dc, RS 485 e.g Modbus
<b>CI2 005VC</b>	0-5ppm 24Vac/dc, RS 485 e.g Modbus
<b>CI2 010VC</b>	0-10ppm 24Vac/dc, RS 485 e.g Modbus
<b>CI2 020VC</b>	0-20ppm 24Vac/dc, RS 485 e.g Modbus

### Addressing and calibration with servicetool

<b>CI2 002VCT</b>	0-2ppm 24Vac/dc, RS 485 e.g Modbus
<b>CI2 005VCT</b>	0-5ppm 24Vac/dc, RS 485 e.g Modbus
<b>CI2 010VCT</b>	0-10ppm 24Vac/dc, RS 485 e.g Modbus
<b>CI2 020VCT</b>	0-20ppm 24Vac/dc, RS 485 e.g Modbus

<b>MOD</b>	Protocol for Modbus
<b>GCD</b>	Protocol for GCD-series
<b>REL</b>	Relay pack see rear side
<b>DUCT</b>	Duct Mounting
<b>LCD</b>	Two lines, 16 characters each
<b>CAL 2</b>	Calibration Kit for Tox-transmitters
<b>HEAT</b>	Temp.controlled heating element 3C +/-2C0,3VA
<b>BUZZ</b>	Internal warning summer 85dB
<b>STAIN</b>	Enclosure of stainless steel
<b>SERV</b>	Service Tool with Keyapad and LCD-display
<b>AIN</b>	4-20mA analogue input
<b>GAS 17</b>	Calibration gas 17 liter
<b>REG</b>	Pressure regulator flow adjusted to 0,5 lit/min.

**Warning devices** See special datasheet

**Warning signs** See special datasheet

### Technical Data

<b>Gas</b>	Chlorine CI2
<b>Detection principle</b>	Electrochemical, diffusion
<b>Measuring range</b>	0 - 10ppm factory set 0-2, 0-5, 0-20ppm (optional)
<b>Accuracy</b>	0,1 ppm
<b>Long term output drift</b>	<2% signal loss/year
<b>Response time</b>	t90 <90 sec.
<b>Repeatability</b>	<2% of reading
<b>Storage time</b>	Max 3 months
<b>Mounting height</b>	<b>0,2 metres above floor</b>
<b>Output signal</b>	(0)4-20mA, load 500ohm Selectable (0)2-10Vdc, load 50kohm Starting point 0/20% Relay 1 30Vac/dc, 0,5A, pot.free SPDT Relay 2 Dito SPNO/SPNC potential free Consumption 30mA, max 0,8VA
<b>Serial Interface</b>	Transciever RS485/19200 Baud/9600 at Mod
<b>Power supply</b>	18-28Vac/dc,reverse polarity prot. for 2-wire mode only Vdc
<b>Power consumption</b>	22mA, max (0,6VA)
<b>Expected lifetime</b>	2 years,normal operating envirom.
<b>Humidity range</b>	15-95% rH non-condensing
<b>Operating range</b>	-10 up to +50C
<b>Rating</b>	IP65 Protection Class
<b>Pressure range</b>	Atmospheric +/-15%

## Physical characteristics

<b>Enclosure</b>	Polycarbonate, halogen-free
<b>Flammability</b>	UL94 V2
<b>Enclosure colour</b>	RAL light grey
<b>Dimensions WxHxD</b>	94 x 130 x 57mm
<b>Weight</b>	approx 0,5kg
<b>Cable entry</b>	Standard 1 x M20
<b>Wire connection</b>	Screw terminal, min 0,25mm <sup>2</sup> and max 2,5mm <sup>2</sup>
<b>Wire distance</b>	Current signal 500m Voltage signal 200m
<b>Guidelines</b>	EMC Directive 2004/108/EEC

## Warning buzzer

<b>Acoustic pressure</b>	85db (distance 300m)
<b>Frequency</b>	3,5 kHz
<b>Power consumption</b>	30mA, (max 0,8VA)

## LCD display

<b>LCD</b>	Two lines, each 16 characters
<b>Power consumption</b>	10mA (max 0,3VA)

## Heating

<b>Temperature controlled</b>	3C +/-2C
<b>Ambient temperature</b>	-40C
<b>Power supply</b>	18-28Vdc/ac
<b>Power consumption</b>	0,3A, 7,5VA

## Analogue input

<b>Only for RS-485 mode</b>	4-20mA overload and short-circuit proof, input resistance 200ohm
-----------------------------	--

<b>Power supply for external transmitter</b>	24Vdc max.50mA
--	----------------

## Connecting Diagram

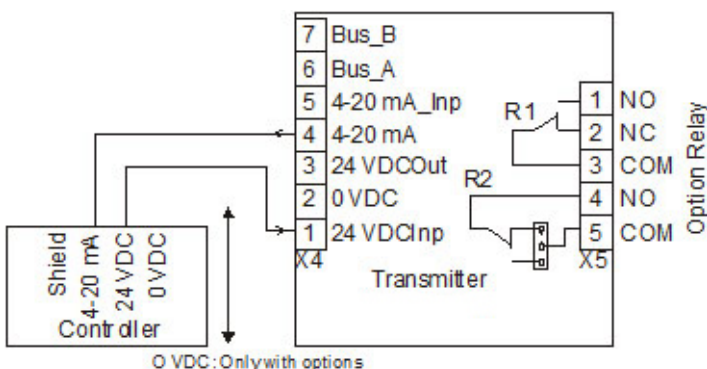

## Relay Package

The two relays are activated in dependence of the gas concentration.

If the gas concentration exceeds the adjusted alarm threshold, the corresponding relay switches on.

If the gas concentration falls below the threshold minus hysteresis, the relay switches off again.

The contact function for relay 2, NC (normally closed) or NO (normally open), can be selected via jumper NO/NC.

See fig.1 and 3.

Relay one is equipped with a change-over contact.

Via the Modbus interface the two alarm thresholds and the hysteresis are freely adjustable at the PC within the measuring range.

The procedure can be read from the user manual Modbus Software.

The following parameters are factory set.

**Alarm threshold 1 = Relay 1: 5ppm**

**Alarm threshold 1 = Relay 2: 8ppm**

**Switching hysteresis: 1ppm**

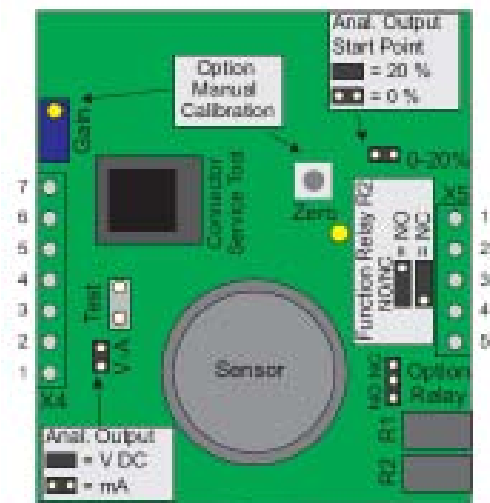

Cross sensitivity<sup>1</sup>  
**Concentration (ppm)**

**Reaction (ppm)**

Carbon monoxide, CO	300	0
Hydrogen, H <sub>2</sub>	300	0
Nitrogen dioxide, NO <sub>2</sub>	20	~ 20
Nitric oxide, NO	35	0
Sulphur dioxide, SO <sub>2</sub>	5	0

<sup>1</sup> The table doesn't claim to be complete.

Other gases can have an influence on the sensitivity, too.

The mentioned cross sensitivity data are only reference values valid for new sensors