

Gas Controller CDA

Analog Gas Controller

User Manual

December 2007

1	Intended Use	4
2	Description	4
3	Operating Instruction	5
3.1	Description of the Keypad User Interface	5
3.2	Setting / Changing of Parameters or Set Points	5
3.3	Code Level	6
4	Menu Overview	7
4.1	Fault Management	8
4.1.1	Acknowledge a Fault	8
4.1.2	Error Memory	8
4.1.3	System Errors	9
4.2	Status Alarm	10
4.3	Status Relay	10
4.3.1	Manual Operation of the Relays	10
4.4	Menu Measuring Values	11
4.5	Menu Relay Parameter	11
4.5.1	Relay Mode	12
4.5.2	Relay Function Static / Flash	12
4.5.3	Latching Mode	12
4.5.4	Horn Function	13
4.5.5	External Relay Operation	14
4.5.6	Delay Mode of the Relay	14
4.6	Menu MP Parameter	14
4.6.1	Activate – Deactivate MP	16
4.6.2	Selection Gas Type	16
4.6.3	Measuring Range	16
4.6.4	MP Signal	17
4.6.5	Threshold / Hysteresis	17
4.6.6	Delay of Alarm ON and/or OFF	17
4.6.7	Control Mode	17
4.6.8	MP Fault Assigned to Alarm	18
4.6.9	Alarm Assigned to Alarm Relay	18
4.6.10	MP Signal Assigned to Analog Output	18
4.7	Menu System Parameter	19
4.7.1	Service Mode	20
4.7.2	Software Version	20
4.7.3	Maintenance Concept	21
4.7.4	Average Function	21
4.7.5	System Time, System Date	21
4.7.6	Customer Password (Code 1)	21
4.7.7	Analog Output	22
4.7.8	Define the Fault Relay	22
4.7.9	Power On Time	22
4.7.10	Registration of Expansion Modules	22

5	Mounting / Electrical Connection	23
5.1	Electrical Connection	23
5.2	Connection Diagram	24
6	Commissioning.....	27
6.1	Commissioning.....	27
6.2	Checklist Commissioning.....	28
7	Configuration and Parameter Card.....	29
7.1	Configuration Card of System Parameters	29
7.2	Configuration Card of Alarm Relays	29
7.3	Configuration Card of Measuring Parameters	30
8	Technical Data	31
9	Module Overview	32
10	Notes and General Information	33
10.1	Intended Product Application.....	33
10.2	Installers' Responsibilities	33
10.3	Maintenance	33
10.4	Limited Warranty	33

Analog Gas Controller System CDA

1 Intended Use

The CDA Gas Controller is used for monitoring and warning of toxic and combustible gases and vapours in the ambient air.

The Gas Controller CDA complies with the regulations according to VDI 2053 January 04, German directive for garages, according to ÖNORM and NVN 2443 for stationary monitoring of Carbon Monoxide (CO), Nitrogen Dioxide (NO₂) and of combustible gases in underground garages, tunnels, go-kart race courses etc.

The Gas Controller can be used as well for monitoring other gases.

The intended sites are all areas being directly connected to **Fehler! Keine Indexeinträge gefunden.** the public low voltage supply, e.g. residential, commercial and industrial ranges as well as small enterprises (according to EN50 082).

The Gas Controller CDA must not be used in potentially explosive atmospheres.

2 Description

The Gas Controller CDA is a measuring, warning and controlling device for continuous monitoring of different toxic, combustible gases and vapours as well as of Freons.

The Gas Controller CDA can control up to 24 analog gas transmitters with 4 to 20 mA signal.

Up to five alarm thresholds are free adjustable for each gas transmitter.

The alarm message is transmitted via potential-free relays.

The operation of the Gas Controller is comfortable and easy thanks to the logical menu structure.

A number of integrated parameters enable the simple and fast configuration of the controller.

3 Operating Instruction

The complete configuration, parameterization and service are made via a keypad user interface in combination with the display screen.

Security is provided via two password levels.

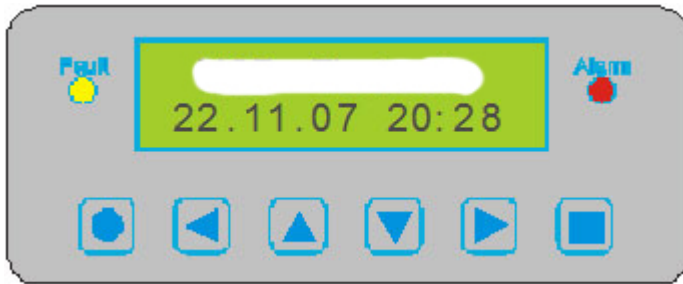

3.1 Description of the Keypad User Interface



Exits programming and saves settings, returns to the previous menu level.



Enter submenus, stores security password..



Scrolls up & down in main menu and submenus, increases or decreases a value.



Moves the cursor.

LED red Flashes when one or more alarms are active. (Alarm threshold exceeded.)

LED yellow: Flashes at system or sensor failure or when maintenance is needed.

3.2 Setting / Changing of Parameters or Set Points

Open desired menu window.



Push the button > Code window opens, if no code level approved.

After input of the valid code the cursor jumps onto the first position segment which can be changed.



Move the cursor onto the position segment, which is to be changed.



Change the parameter / set point.



Save the changed value.

Finished.

3.3 Code Level

All changes of parameters and set point values are protected by a four-digit numeric code (= password).

The code level 1 permits the operation of the CDA.

This code level is intended for the customer.

The code can be changed individually via code level 2.

In code level 2 all parameters and set points are released, this code level is only for the service technician.

Additionally a third code level permits to activate or deactivate measuring points (MP) and expansions modules (EP).

The release of the code level is deleted if no button is pushed within 15 minutes.

All menu windows are visible without entering any code.

4 Menu Overview

The operation of the Gas Controller CDA is managed by a simple and logical menu structure which is easy to learn. The operating menu contains the following levels:

- Starting menu with date and time.
- Main menu
- Submenus 1 and 2

Starting menu

Main menu

Submenu

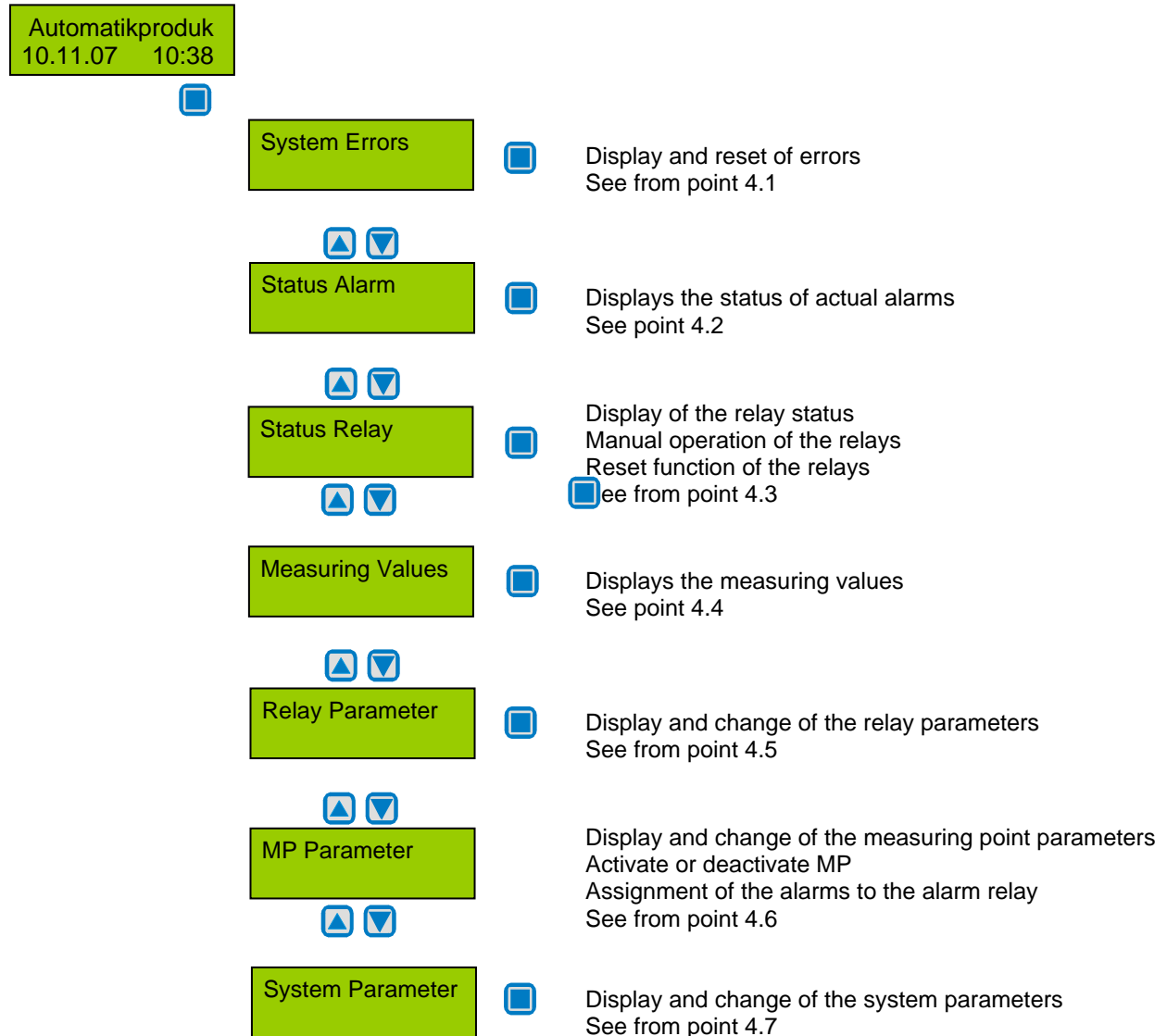

4.1 Fault Management

The integrated fault management records the last 15 faults with date and time stamps in the menu "System Errors". Additionally a record of the faults occurs in the "Error memory", which can be selected and reset only by the service technician.

An actual fault is displayed in plain text in the starting menu.

The fault relay which is defined in the system parameter "Fault Relay" is activated.

The yellow LED in the front of the gas controller flashes.

In case of the failure of a connected transmitter the alarms defined in the menu "MP Parameter" are activated additionally.

4.1.1 Acknowledge a Fault

Attention:

Acknowledging a fault is only possible after having removed the cause.

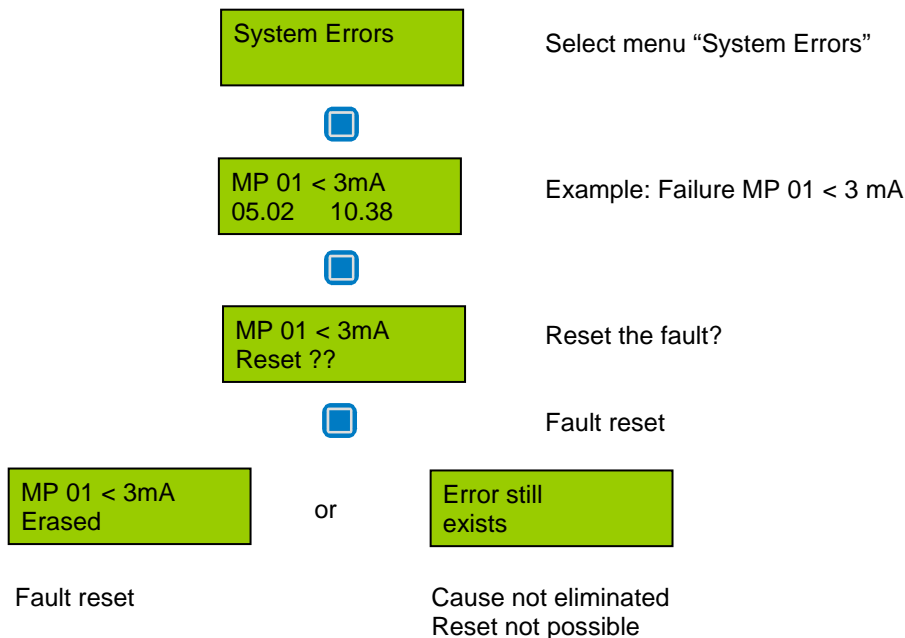

4.1.2 Error Memory

The menu "Error Memory" in the main menu "System Errors" can only be opened via code level 2.

In the error memory the last 15 faults are listed for the service technician even if they were already acknowledged in the menu "System Errors". The deletion of each individual message is effected in the same way as the reset of a fault.

4.1.3 System Errors

The following system error messages are recorded:

MP XX > 22 mA	Current signal at analog input XX > 22 mA.
Cause:	Short-circuit at analog input or transmitter not calibrated, transmitter defective.
Solution:	Check cable to transmitter, make calibration, replace the transmitter.
MP XX < 3 mA	Current signal to analog input XX < 3 mA.
Cause:	Wire breaking at analog input or transmitter not calibrated, transmitter defective.
Solution:	Check cable to transmitter, make calibration, replace the transmitter.
GC Error:	Internal communication error I/O board to LCD board.
Cause:	Internal error.
Solution:	Exchange the Gas Controller module.
EP 0X Com Error:	Communication error to expansion module (EP 04 XX). (Only active, if an EP 04 registered).
Cause:	EP module address not correct (see Commissioning 5.0). Bus cable to EP 04 XX module disconnected. No power supply at the EP module. EP module defective.
Solution:	Check the EP module address. Check the bus cable and the power supply. Exchange the EP module.
Maintenance:	System maintenance is necessary.
Cause:	Maintenance date exceeded.
Solution:	Make the maintenance.

4.2 Status Alarm

Display of the actual alarms in plain text in the order of their arrival.

Only those measuring points are displayed, where at least one alarm is active.

Changes are not possible in this menu.

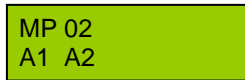

Symbol	Description	Function
MP 02	Measuring Point (MP) No.	
AX	Status Alarm	A1 = Alarm 1 ON A2 = Alarm 2 ON A3 = Alarm 3 ON A4 = Alarm 4 ON A5 = Alarm 5 ON

4.3 Status Relay

Display of the actual status of alarm relays. Manual operation of the alarm relays.



Symbol	Description	Setting Status	Function
R 01	Relay No. 01		Select Relay No.
OFF	Status Relay	OFF	OFF = Relay OFF (no gas alarm) ON = Relay ON (gas alarm) Manual OFF = Relay manual OFF Manual ON = Relay manual ON

4.3.1 Manual Operation of the Relays

The manual operation of the alarm relays is managed in the menu "Status Relay".

If a relay is in the manual ON or OFF status, the alarm LED at the Gas Controller is lit continuously.

The external operation of the alarm relay via an assigned digital input has priority to the manual operation in the menu "Status Relay" and to gas alarm.

Relays manually operated in the menu "Status Relay" are deleted again by selecting the function "Automatic".

Acknowledging the relays by latching mode is also effected in this menu.

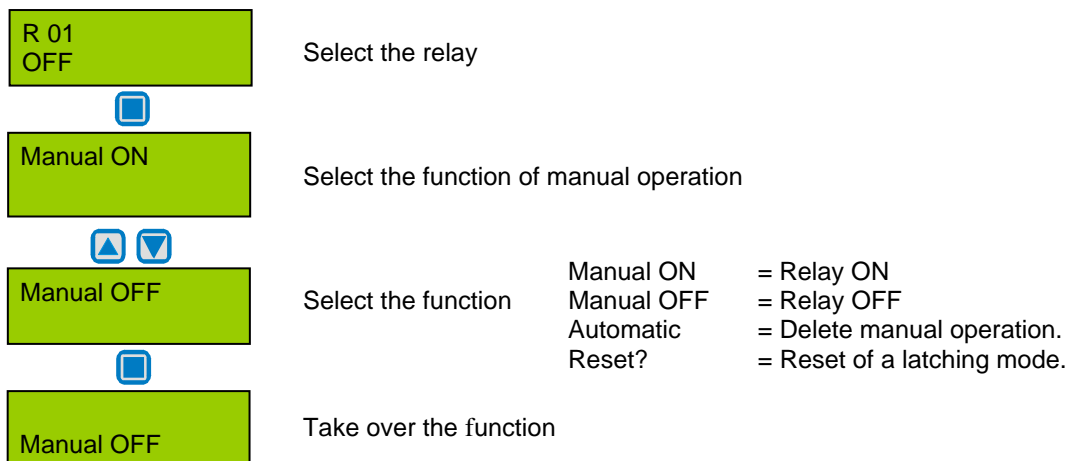

4.4 Menu Measuring Values

In this menu the current value (CV) and average value (AV) for each active measuring point (MP) are displayed including gas unit and gas type as well as the defined control mode (CV or AV mode).

MP 01 CO ppm
50 *AV 33 CV

Symbol	Description	Setting Status	Function
MP 01	Measuring P.No.		Select MP No.
CO	Gas type	CO	See 4.6.2
ppm	Gas unit		See 4.6.2
CV	Current value	CV	Current value of the gas concentration
AV	Average value		Average value (10 measured values within the time unit)
*	Control mode		Display of selected control mode. (CV or AV)
Not active	Status MP	Not active	MP not active
Error	Fault MP		Current signal < 3 mA or > 22 mA

4.5 Menu Relay Parameter

Display and change of the parameters for each alarm relay.

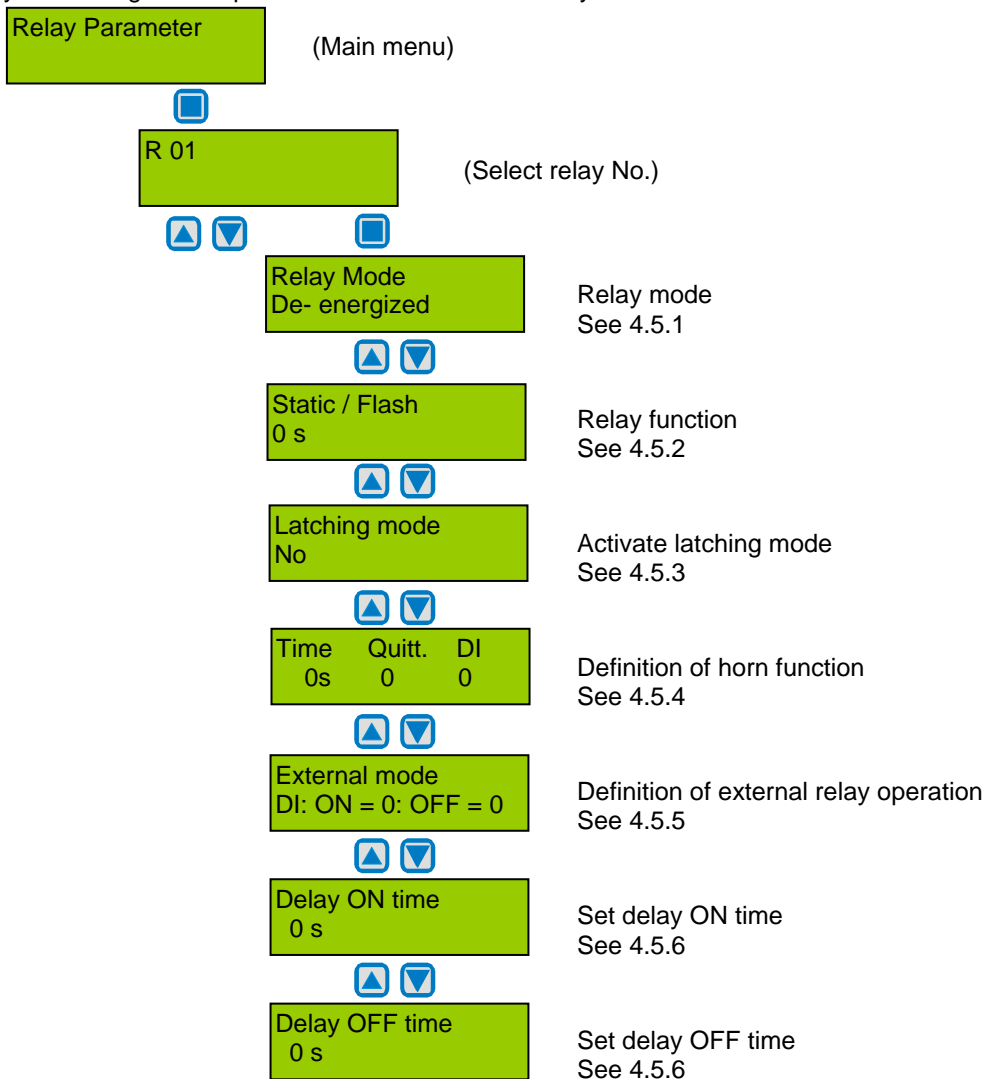

4.5.1 Relay Mode

Definition of relay mode:

Symbol	Description	Setting Status	Function
R 01	Relay No.		Selection of a relay
De-energized	Relay Mode	De-energized	De-energized = Alarm ON = Relay ON Energized = Alarm ON = Relay OFF

4.5.2 Relay Function Static / Flash

Definition of relay function

Symbol	Description	Setting Status	Function
R 01	Relay No.		Selection of a relay
0	Function	0	0 = Relay function static > 0 = Relay function flashing (= Time period in sec.) Impulse / Break = 1:1

4.5.3 Latching Mode

Definition of latching function

Symbol	Description	Setting Status	Function
R 01	Relay No.		Selection of a relay
No	Latching Mode	No	No = Latching mode not active Yes = Latching mode active

Acknowledging a latching relay in the menu "Status Relay" is only possible if the gas concentration is again lower than the alarm threshold including hysteresis. In this case the status latching occurs in the display.

Example: Alarm relay R2 with latching mode

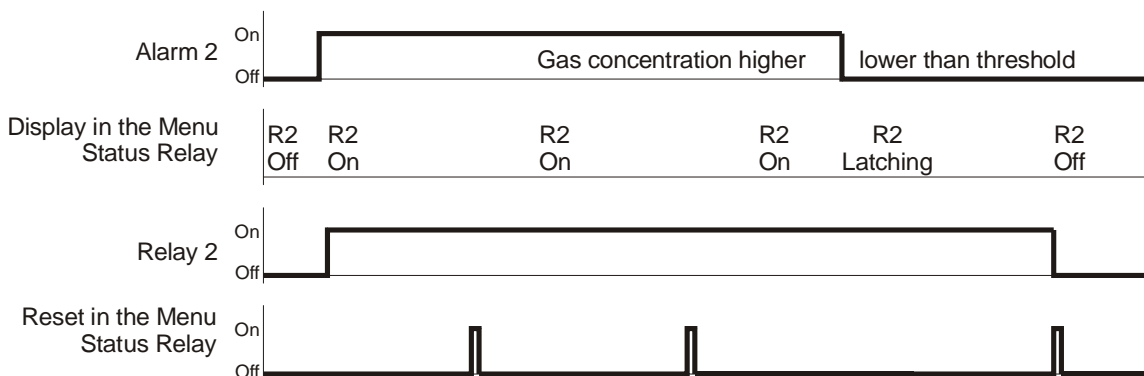

4.5.4 Horn Function

The alarm relay is defined as horn relay by this parameter with the following possibilities to reset.

- By pressing any of the 6 push-buttons (only possible in the starting menu).
- Automatic reset at the end of the fixed time.
- By an external push-button (assignment of the appropriate digital input).

The horn function is only activated if at least one of the two parameters (time or digital input) is set.

Special function: Response

After acknowledging the relay (by push-button or externally) time starts. When this time has run out and the alarm is still acting, the relay is set again.

Symbol	Description	Setting Status	Function
R 04	Relay No.		Selection of a relay
Quitt	Mode	0	0 = Reset of the relay after time having run out, or via DI 1 = Reset of the relay via DI, after time having run out, relay is set again. (Response function).
Time		120	Time for function of automatic reset or response function 0 = no reset function
DI		0	Assignment, which digital input resets the relay.

Acknowledge the horn relay

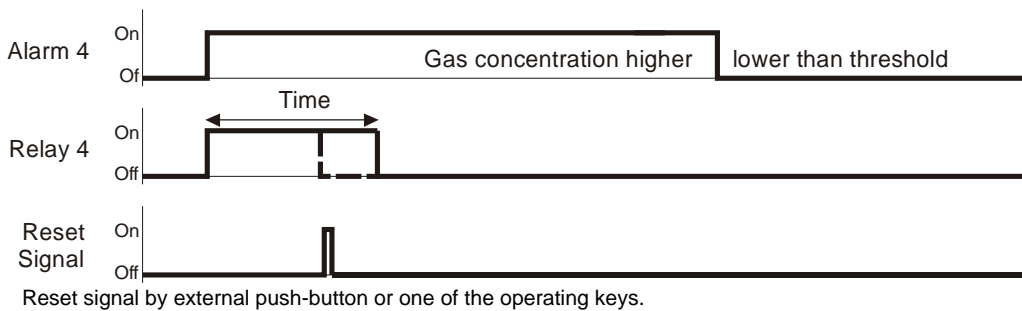

Reset signal by external push-button or one of the operating keys.

Special function „Response“. (Return of the horn relay)

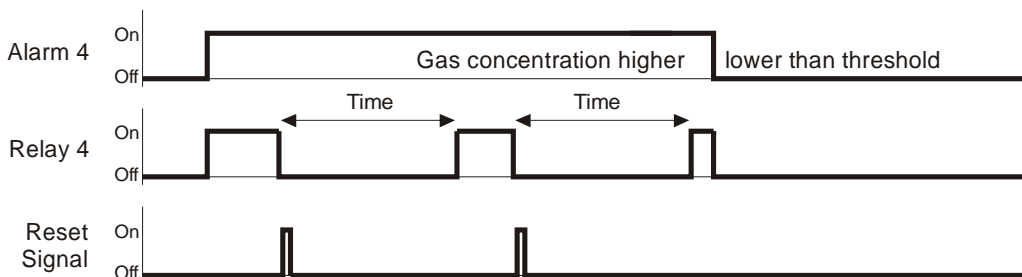

Reset signal by external push-button or one of the operating keys.

4.5.5 External Relay Operation

Assignment of a digital input (DI) for external switching of the alarm relay (ON and/or OFF).

This function has priority to a gas alarm and/or manual switching in the menu “Status Relay”.

Symbol	Description	Setting Status	Function
R 01	Relay No.		Selection of a relay
DI-ON	External On	0	If digital input closed, relay switches ON
DI-OFF	External Off	0	If digital input closed, relay switches OFF

4.5.6 Delay Mode of the Relay.









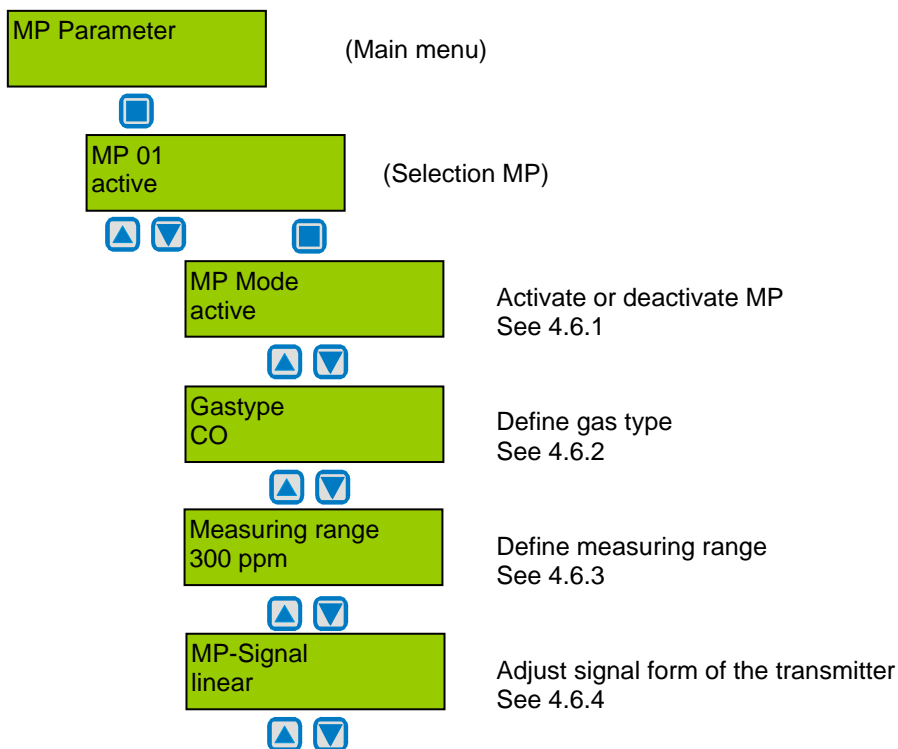













Delay ON time starts when the alarm is released and/or delay OFF time starts when the alarm returns to normal condition.

Symbol	Description	Setting Status	Function
R 01	Relay No.		Selection of a relay
0 s	Delay Time ON	0	Mode ON: Relay is only activated at the end of the defined time (sec.) 0 sec. = No delay
0 s	Delay Time OFF	0	Mode OFF: Relay is only deactivated at the end of the defined time (sec.) 0 sec. = No delay

4.6 Menu MP Parameter

Display and change of parameters, assignment of alarms to alarm relays and activation of each Measuring Point (MP).



Threshold 1 40 ppm  	Define threshold 1 See 4.6.5
Threshold 2 80 ppm  	Define threshold 2 See 4.6.5
Threshold 3 100 ppm  	Define threshold 3 See 4.6.5
Threshold 4 120 ppm  	Define threshold 4 See 4.6.5
Threshold 5 300 ppm  	Define threshold 5 See 4.6.5
Hysteresis 15 ppm  	Hysteresis See 4.6.5
Delay ON time 0 s  	Set delay ON time See 4.6.6
Delay OFF time 0 s  	Set delay OFF time See 4.6.6
C/A Mode CV  	Define control mode See 4.6.7
Alarm - 1 2 3 4 5 Fault - 1 1 0 0 0  	Assign MP fault to alarm See 4.6.8
A1; A2; A3; A4; A5 01; 02; 03; 04; 05  	Assign alarm to alarm relay See 4.6.9 and 4.6.10
Analog Output 0	Assign MP signal to analog output See 4.6.10

4.6.1 Activate – Deactivate MP

Symbol	Description	Setting Status	Function
MP 01	Measuring Point		Selection MP No.
Active	MP Status	Not active	Active = Measuring point activated at the controller Not active = Measuring point not activated at the controller

4.6.2 Selection Gas Type

Assign gas type to attached gas transmitters.

Symbol	Description	Setting Status	Gas type		Unit	Measuring range ¹
MP 01	Measuring point					
NH ₃	Gas type	NH ₃	CO	Carbon monoxide	ppm	0 – 300
			Ex	Combustible gas	%LEL	0 – 100
			NO	Nitrogen oxide	ppm	0 – 50
			NO ₂	Nitrogen dioxide	ppm	0 – 25
			NH ₃	Ammonia	ppm	0 – 300
			O ₂	Oxygen ²	%V/V	0 – 25
			CO ₂	Carbon dioxide	ppm	0 – 2000
			SO ₂	Sulphur dioxide	ppm	0 – 100
			H ₂ S	Hydrogen sulphide	ppm	0 – 200
			CL ₂	Chlorine	ppm	0 – 100
			ETC	Ethylene oxide	ppm	0 – 20
			VOC	Air quality	%	0 – 100
			TOX	Toxic gas	ppm	0 - xx
			R401	Refrigerant gas	ppm	0 – 2000
			R402	Refrigerant gas	ppm	0 – 2000
			R408	Refrigerant gas	ppm	0 – 2000
			R409	Refrigerant gas	ppm	0 – 2000
			R404	Refrigerant gas	ppm	0 – 300
			R416	Refrigerant gas	ppm	0 – 300
			R502	Refrigerant gas	ppm	0 – 300
R410	Refrigerant gas	ppm	0 – 300			
R411	Refrigerant gas	ppm	0 – 300			
R11	Refrigerant gas	ppm	0 – 300			
R123	Refrigerant gas	ppm	0 – 300			
R134	Refrigerant gas	ppm	0 – 300			
R22	Refrigerant gas	ppm	0 – 300			
TEM	Temperature	°C	0 – 50			
RH	Humidity	% RH	0 – 100			

¹ Recommendation without obligation

² Decreasing signal at oxygen measurement!

4.6.3

Measuring Range

The measuring range can be defined freely within 10 to 10000.

The measuring ranges in the table “Gas Type” are only recommendations without obligation.

The measuring range must agree with the signal (4 to 20 mA) of the attached gas transmitter.

(4 mA = Display 0 (ppm), 20 mA = Display of the ultimate value of the measuring range)

4.6.4 MP Signal

Gas transmitter using electro-chemical - or catalytic beat gas sensors normally produce a linear 4 to 20 mA signal, proportional to the gas concentration.

Semiconductors gas sensors produce a non-linear (exponential) signal.

This signal leads to a non linear 4 to 20 mA signal of the gas transmitter.

The Gas Controller CDA is prepared for both types of gas transmitters. The signal mode is defined in this menu.

Symbol	Description	Setting Status	Function
MP 01	Measuring Point		Selection of MP No.
Linear	MP Signal	Linear	Linear = Transmitter with linear output signal Non linear = Transmitter with non-linear output signal (only series AT from MSR-E)

4.6.5 Threshold / Hysteresis

For each measuring point five alarm thresholds are available for free definition.

If the gas concentration is higher than the adjusted alarm threshold, the associated alarm is set.

If the gas concentration falls below the alarm threshold inclusive hysteresis the alarm is reset again.

Unused alarm thresholds have to be defined at measuring range end point, in order to avoid false alarms.

At O₂ measurement an alarm is released by a decreasing measuring signal!

Symbol	Description	Default Status		Function
MP 01	Measuring Point			Selection MP No.
40 ppm	Threshold	40 80 100 120 300 15	Threshold 1 Threshold 2 Threshold 3 Threshold 4 Threshold 5 Hysteresis	Gas- concentration > Threshold 1 = Alarm 1 Gas- concentration > Threshold 2 = Alarm 2 Gas- concentration > Threshold 3 = Alarm 3 Gas- concentration > Threshold 4 = Alarm 4 Gas- concentration > Threshold 5 = Alarm 5 Gas- concentration < (Threshold X –Hysteresis) = Alarm X OFF

4.6.6 Delay of Alarm ON and/or OFF

Definition of alarm ON and/or alarm OFF delay. The function applies to all alarms of an MP.

Symbol	Description	Default Status	Function
MP 01	Measuring Point		Selection of MP No.
0 s	Delay ON Time	0	Gas concentration > Threshold: Alarm is only activated at the end of the fixed time (sec.). 0 sec. = No delay
0 s	Delay OFF Time	0	Gas concentration < Threshold: Alarm is only deactivated at the end of the fixed time (sec.). 0 sec. = No delay

4.6.7 Control Mode

Definition of the alarm evaluation by means of current (CV) or average value (AV)

Symbol	Description	Default Status t	Function
MP 01	Measuring Point		Selection of MP No.
CV	Evaluation	CV	CV = Control by the current gas value AV = Control by the average gas value

Current- average value function See: 4.7.4

4.6.8 MP Fault Assigned to Alarm

Definition, which alarms are activated in case of a fault at the measuring point.

Symbol	Description	Default Status	Function
MP 01	Measuring Point		Selection of MP No.
Alarm - 1 2 3 4 5 Fault - 1 1 0 0 0	Failure MP	1 1 0 0 0	0 = Alarm not ON at MP failure 1 = Alarm ON at MP failure

4.6.9 Alarm Assigned to Alarm Relay

Each of the 5 alarms can be assigned to any alarm relay. Unused alarms are not assigned to any alarm relay.

Symbol	Description	Default Status	Function
MP 01	Measuring Point		Selection of MP No.
01	A1	01	01 = Alarm 1 activates alarm relay R 01
	A2	02	02 = Alarm 2 activates alarm relay R 02
	A3	03	03 = Alarm 3 activates alarm relay R 03
	A4	04	04 = Alarm 4 activates alarm relay R 04
	A5	00	00 = Alarm 5 doesn't activate any alarm relay

4.6.10 MP Signal Assigned to Analog Output

The measuring point signal can be assigned to one of the analog outputs. Then the signal defined in the control mode (current or average value) is transmitted.

Symbol	Description	Default Status	Function
MP 01	Measuring Point		Selection of MP No.
0x	A	0	0 = MP Signal not assigned to any analog output 1 = MP Signal assigned to analog output 1 2 = MP Signal assigned to analog output 2

Analog output see also: 4.7.2

4.7 Menu System Parameter

Display and changes of the system parameters of the Gas Controller module

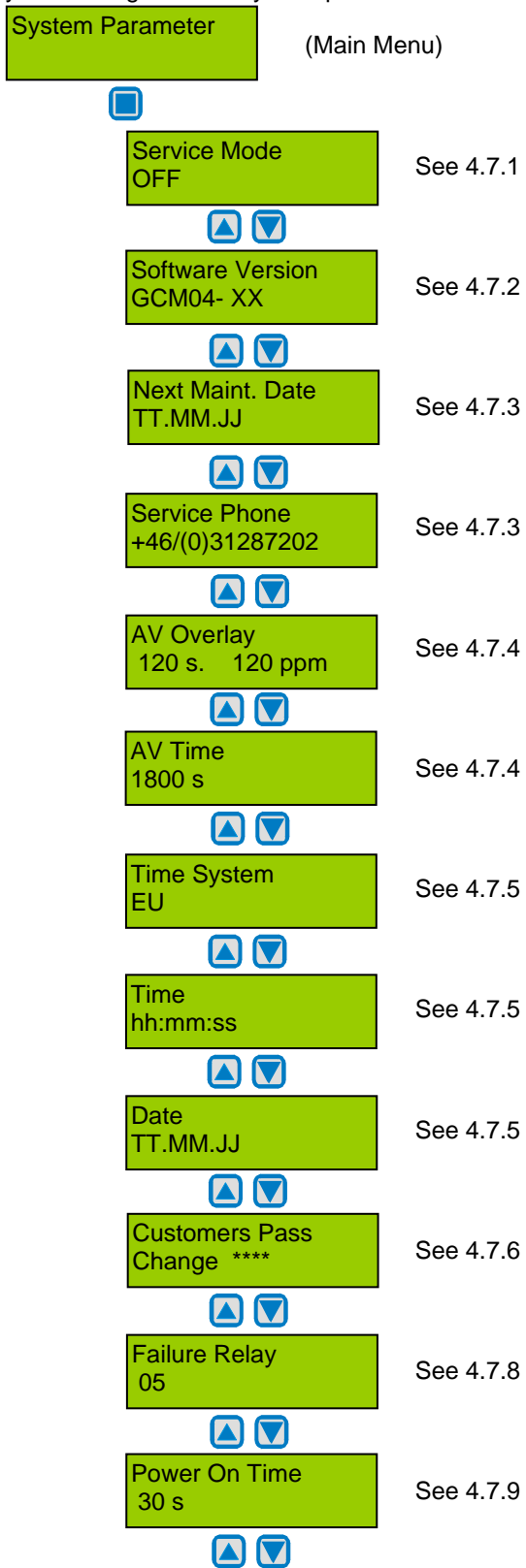

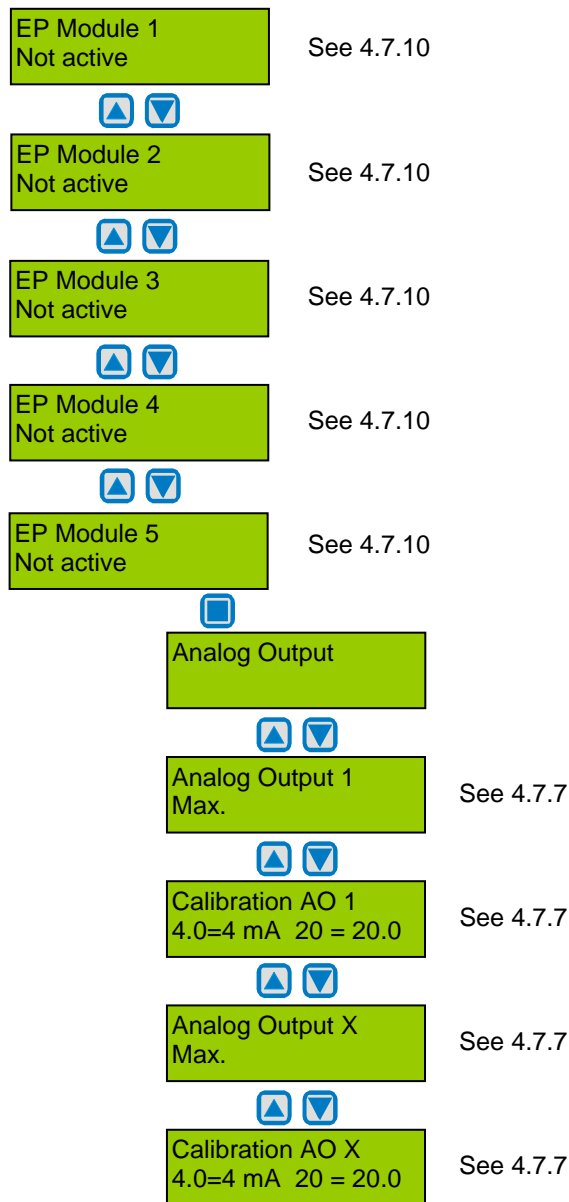

4.7.1 Service Mode

When the service mode is active (ON) the alarms are not transmitted to the alarm relays (in case of calibration or service work).

The service mode is reset automatically after 60 minutes or manually in the menu “Service Mode”.

Symbol	Description	Default Status	Function
Off	Service Mode	Off	Off = Alarms activate the associated alarm relays On = Alarms are not transmitted to the alarm relays

4.7.2 Software Version

Symbol	Description	Default Status	Function
CG04-XX	Software Version		XX = Software Version

4.7.3 Maintenance Concept

A control of the maintenance intervals required by law or by customer is integrated in the CDA system.

At commissioning or after maintenance the date for next maintenance is entered.

When reaching this date the failure signal is activated the next morning at 9 o'clock, and the phone no. of the service technician occurs in the display.

The fault signal (maintenance) can be acknowledged by the operator.

The maintenance message (service phone no.) is reset by entering the next maintenance date after having accomplished the maintenance.

The service phone no. can be entered individually in the next menu.

Symbol	Description	Default Status	Function
TT.MM.JJ	Maintenance Date		TT.MM.JJ = Input of the date for next maintenance.
0853....	Phone No.		Input of the individual service phone no.

4.7.4 Average Function

For each active measuring point the Gas Controller module calculates the arithmetic average value out of 10 measurements got within time unit defined in the menu "AV-time".

This average value is indicated in the menu "Measuring Values" next to the current value.

At each measuring point the control mode (current or average value) is defined for the evaluation of the alarm.

The alarm evaluation of the control mode average value is overlaid by the current value, when the current value exceeds the alarm threshold defined in the menu "AV Overlay".

The overlay is delayed by the time factor defined in this menu.

The time factor being 0s, the AV overlay is not activated.

Symbol	Description	Default Status	Function
120 s 120 ppm	AV Overlay	120 s 120 ppm	sec. = Delay time average value overlay. 0 = No overlay function ppm = Threshold of average overlay
1800 s	AV Time	1800 s	sec. = Time for calculation of the average value

4.7.5 System Time, System Date

Input and correction of time and date. Selection of the time and date format.

Symbol	Description	Default Status	Function
EU	Time format	EU	EU = Display of time and date in EU format US = Display of time and date in US format
hh.mm.ss	Time		hh.mm.ss = Input of the correct time (EU format) hh.mm.ss am = Input of the correct time (US format)
TT.MM.JJ	Date		TT.MM.JJ = Input of the correct date (EU format) MM.TT.JJ = Input of the correct date (US format)

4.7.6 Customer Password (Code 1)

Change the system password for level 1

Symbol	Description	Default Status	Function
1234	Customer-password	1234	1234 = Define the customer's password with 4 characters

4.7.7 Analog Output

The GC-04 module as well as each active EP-04 module has two analog outputs (AO) with 4 to 20 mA signal.

The signal of one or more measuring points can be assigned to each of the analog outputs.

The assignment is effected in the menu "MP Parameter" for each MP.

The measuring point sends the signal, which is defined in the menu "C/A Mode".

Out of the signals of all assigned measuring points the Gas Controller module determines the minimum, the maximum or the average value and transmits it to the analog output.

The definition, which value is transmitted, is effected in the menu "Analog Output X".

The analog output can be calibrated at 4 and at 20 mA.

Therefore an ampere meter (measuring range 25 mA) can be attached to the AO and the respective factor has to be changed until the analog output corresponds to 4 and/or 20 mA. During calibration evaluation of the measuring point signals is not possible.

This calibration is effected by the factory. The factors should not be changed.

Symbol	Description	Default Status	Function
Max.	Select Output Mode	Max.	Min. = Output of the minimum value of all assigned MP Max. = Output of the maximum value of all assigned MP Average = Output of the average value of all assigned MP
4.0 20.0	Calibration	4.0 20.0	4. = Calibration factor at 4 mA 20.0 = Calibration factor at 20 mA

4.7.8 Define the Fault Relay

Definition of the fault relay. See also fault management (4.1)

Symbol	Description	Default Status	Function
05	Fault Relay	R05	R05 = Define the fault relay

4.7.9 Power On Time

Gas sensors need a running-in period, until the chemical process of the sensor reaches stable conditions. During this running-in period the current signal can lead to an unwanted releasing of a pseudo alarm. Therefore the Power On Time is started at the Gas Controller module after having switched on of the power supply. While this time is running out, the Gas Controller does not activate any alarms. The power on status occurs in the starting menu.

Symbol	Description	Default Status	Function
30 s	Power On Time	30 s	XX = Define the power on time (sec.)

4.7.10 Registration of Expansion Modules

The Gas Controller can manage up to five expansion modules (EP-04). Each EP-04 has four analog inputs and five alarm relays. Each attached EP-04 is activated in this menu. The Controller checks the communication to the registered EP-04 modules and shows a fault signal in case of a communication error. To recognize the position of the EP-04 modules a module address is assigned to each module via the address selector. See table.

The table shows the assignment of the MP and relay numbers to the individual modules.

Symbol	Description	Default Status	Function	Module Address	Relay No.	MP No.	AO No.
Not active	EP- Module No 1	Not active	Active = EP activated	1	06 to 10	05 to 08	03 to 04
	EP- Module No 2	Not active		2	11 to 15	09 to 12	05 to 06
	EP- Module No 3	Not active		3	16 to 20	13 to 16	07 to 08
	EP- Module No 4	Not active	Not active = EP not activated	4	----	17 to 20	09 to 10
	EP- Module No 5	Not active		5	----	21 to 24	11 to 12

5 Mounting / Electrical Connection

The Gas Controller is fixed to the wall through the 4 marked mounting holes at the back side of the housing. These mounting holes are accessible after opening the housing. See Fig. 01

The dimensions XX depend on the GCM-04 type and can be read from the back side of the housing. The mounting holes are covered with the enclosed caps after the end of the assembly.

We recommend considering the following when choosing the mounting position:

- Installation height approx. 1.6 m for easy operation.
- Cables are introduced both, from above and from below.
- Keep at least 150 mm of distance on the left side in order to open the transparent door.
- Customer's instructions.

Fig. 01

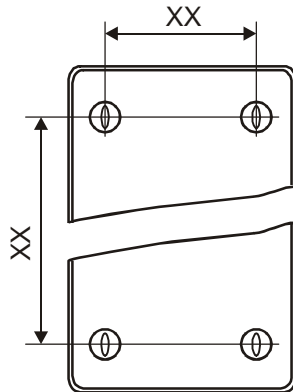

5.1 Electrical Connection

The technical requirements and regulations for wiring, electrical security, as well as project specific and environmental conditions etc. must be observed when mounting.

The electrical installation may only be completed by a qualified electrician in full compliance with pertinent regulations

We recommend the following cable types¹:

- Power supply NYM-J 3 x 1,5 mm²
- Alarm relay NYM-J X x 1,5 mm²
- Gas transmitter J-Y(St)Y 2x2 x 0,8

¹ The recommendation does not consider local conditions such as fire protection etc.

The gas transmitters are connected directly to the module by means of spring-type terminals.

Observe the correct polarity.

The alarms are also connected directly to the module by means of spring-type terminals.

The output terminals of the alarm relays have 2 contacts each for transmitting the signals.

The alarms are available as SPDT, potential-free contacts. If necessary power supply voltage is available at the terminals L1.

For the exact position of the terminals for the transmitters and the alarm relays see the following connection diagram.

The connection diagram shows the GCM-04 module and the maximum number of expansion modules.

Depending on the Gas Controller type, however, only several modules are integrated.

5.2 Connection Diagram

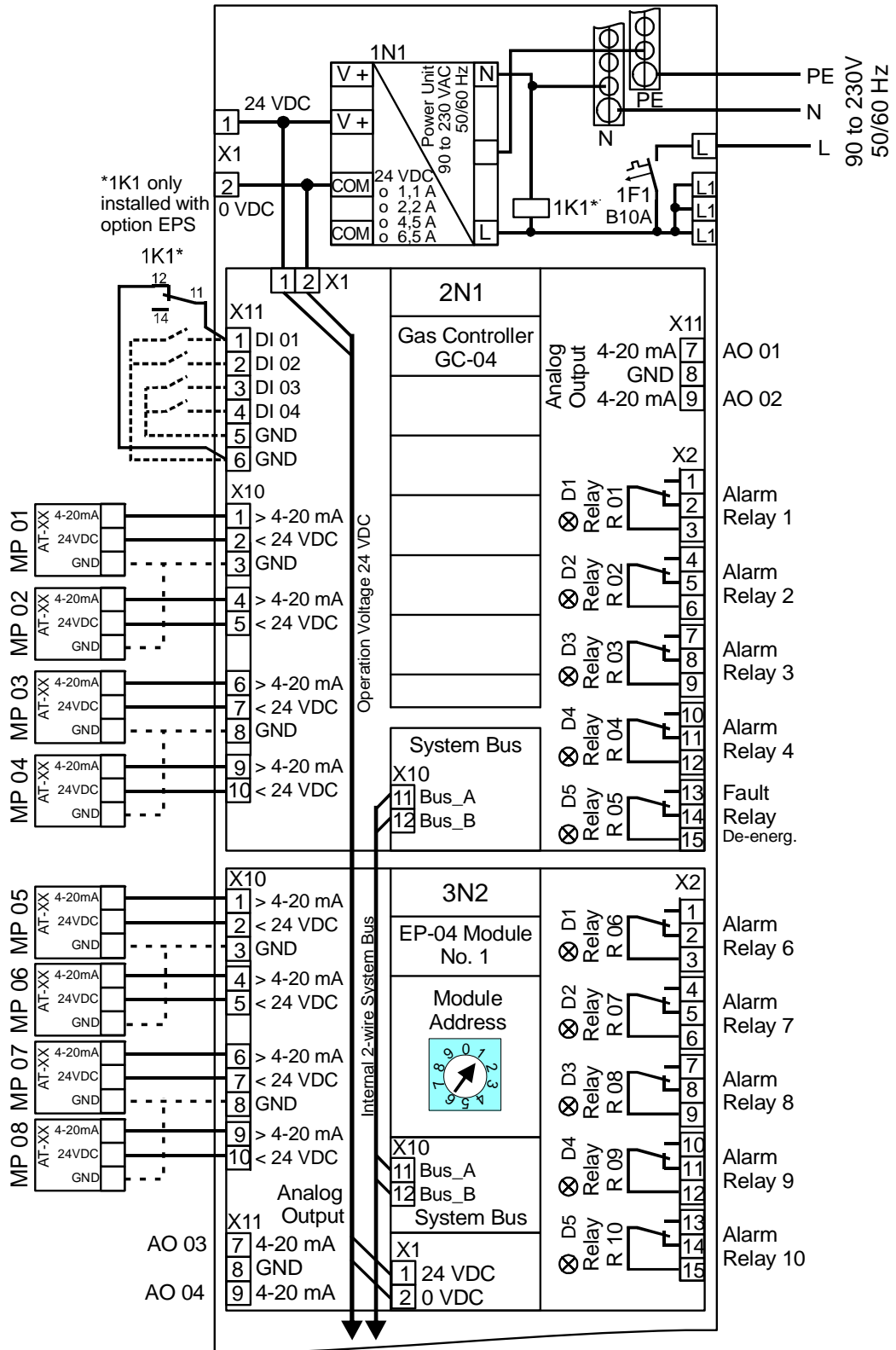

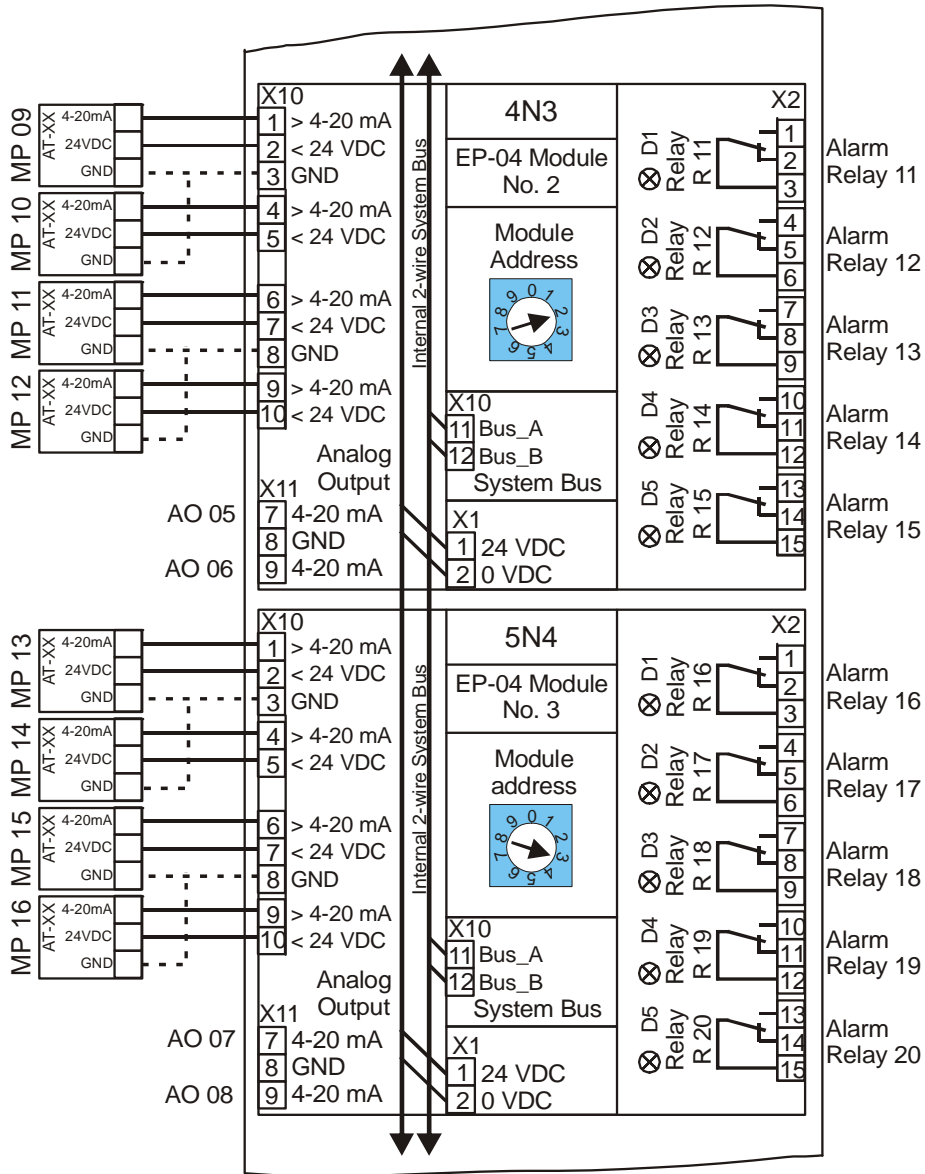

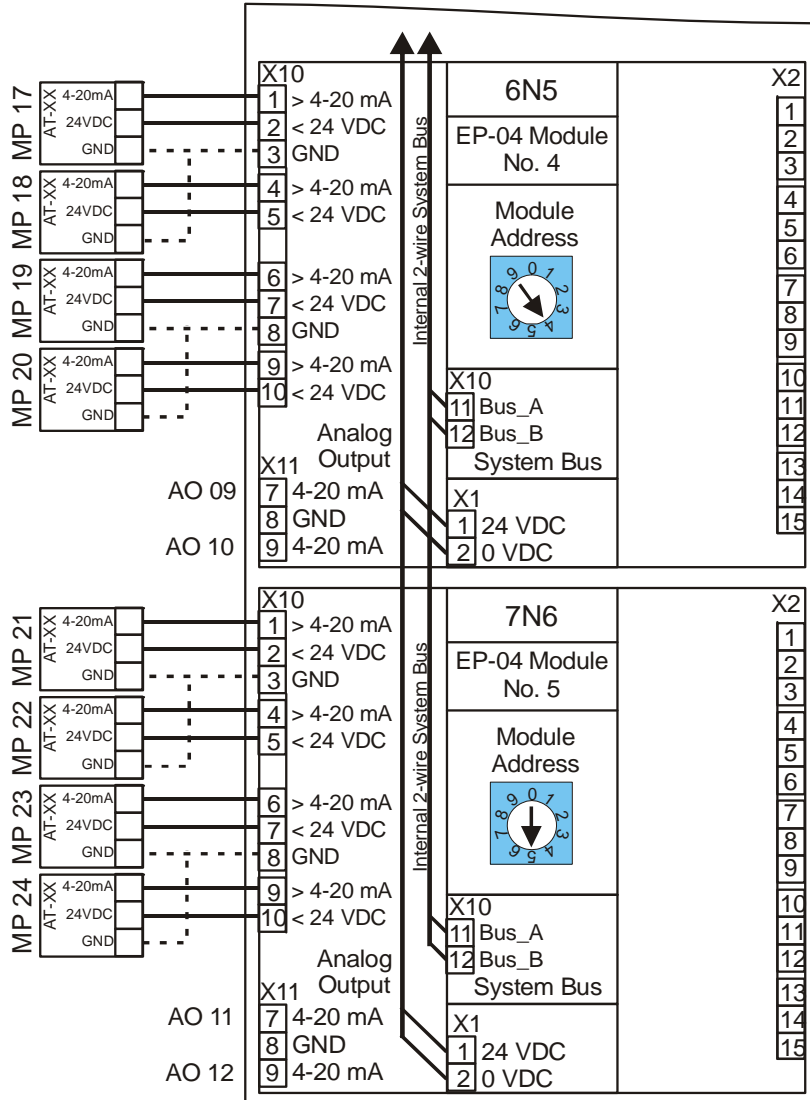

6 Commissioning

6.1 Commissioning

Prior to commissioning, the wiring of the Gas Controller including all field devices must be completely terminated!

If EP-04 modules are attached, the module addresses must be checked at each module according to the following table and if necessary corrected before switching on the supply voltage.

The address switch for adjusting the module addresses is accessible after taking off the contact strip X1 (power).

Module designation (Yellow Label)	Module address (switch position)	MP No.	Relay No.	Analog Output No.
3N2	1	5 to 8	5 to 10	03 to 04
4N3	2	9 to 12	11 to 15	05 to 06
5N4	3	13 to 16	16 to 20	07 to 08
6N5	4	17 to 20	----	09 to 10
7N6	5	21 to 24	----	11 to 12

After switching the power supply "ON" and at the end of the Power On Time, the Gas Controller module is ready for use.

The Gas Controller module is delivered with standard parameter and set points.

The registration of the attached gas transmitters and the assignment of the alarm relays to the individual alarms must always be performed during commissioning.

In addition all other parameters have to be checked and adapted to the local conditions.

The standard parameter can be taken from the following configuration and parameter card.

We recommend registering the individual parameters and set points into the list.

We recommend checking the parameters and set points according to the following check list.

8 Technical Data

Electrical	
Power supply	110/230 VAC 50/60Hz; 24 VAC/DC -10% + 20%
Power consumption (incl. max. AT)	
GCM-04-04-04	13 VA
GCM-04-12-XX	27 VA
GCM-04-20-XX	55 VA
GCM-04-24-XX	65 VA
Option emergency power supply (EPS)	Supply duration 60 minutes
Analog input (max. 24)	4 to 20 mA, overload and short circuit protected, input resistor 200 Ω
Power supply for external analog transmitters	24 VDC max. 50 mA / per channel
Analog output	4 to 20 mA, overload and short circuit protected, max. load 500 Ω
Alarm relays (max. 20)	250 VAC, 5 A, potential-free, SPDT
Failure relay	250 VAC, 5 A, potential-free, SPDT
Option buzzer - Sound pressure	87 dB (distance 1000 mm)
- Frequency	3,5 kHz
Visualization	
LCD	Two lines, each 16 characters, illumination
Status LED	Red = Status Alarm; Yellow = Failure
Operation	6 push-buttons
Gases¹	
External gas transmitter	See 4.6.2, table "Gas Transmitters"
Environmental	
Humidity	15 – 95 % RH non condensing
Working temperature	- 10° C to + 40° C
Storage temperature	0° C to + 40° C
Physical	
Enclosure ²	Plastic housing with transparent cover
Colour ²	RAL 7035 (gray)
Protection class ²	IP 65
Weight ²	
GCM-04-04-04	2,7 kg (6.0 lbs.)
GCM-04-12-XX	4,0 kg (9.0 lbs.)
GCM-04-20-XX	6,0 kg (13.5 lbs.)
GCM-04-24-XX	7,5 kg (16.5 lbs.)
Mounting	Wall mounting
Cable entry	M 16; M 20; M 25
Wire connection: Power supply	Screw type: 2,5 mm ² (14 AWG)
Relay	2 x spring type: 0,5 to 1,5 mm ² (22 to 16 AWG)
Input	Spring type: 0,5 to 1,5 mm ² (22 to 16 AWG)
Dimensions: ¹	(W x H x D)
GCM-04-04-04	298 x 260 x 140 mm (11.7 x 10.2 x 5.5 in.)
GCM-04-12-XX	298 x 420 x 140 mm (11.7 x 16.5 x 5.5 in.)
GCM-04-20-XX	298 x 570 x 140 mm (11.7 x 22.5 x 5.5 in.)
GCM-04-24-XX	410 x 655 x 140 mm (16.1 x 25.8 x 5.5 in.)
Guidelines	EMC Directives 89/336/EEC; CE Low Voltage Directive 73/23/EEC VDI 2053
Warranty	One year material and workmanship

² Only for plastic housing

9 Module Overview

Gas Controller GC 04

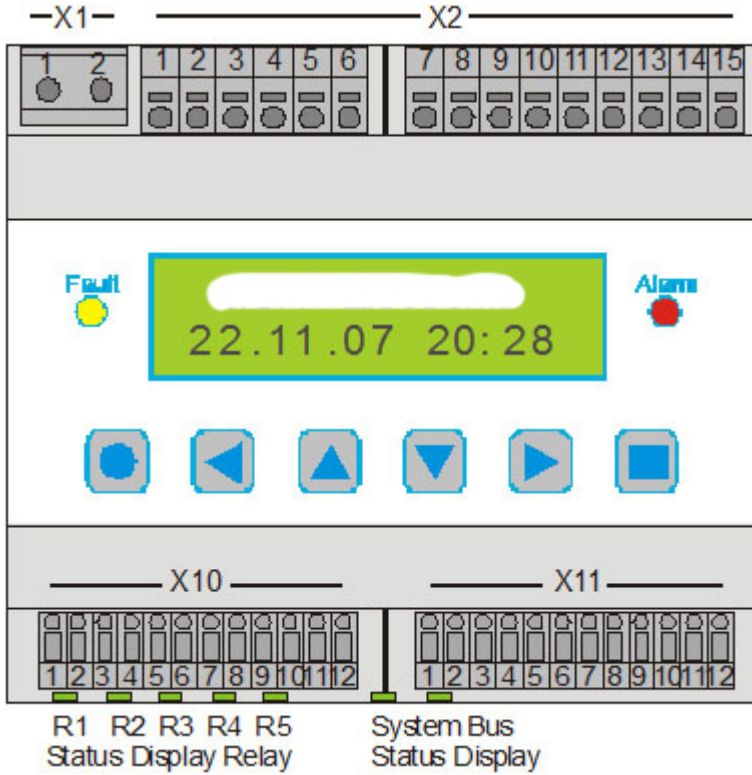

Expansion Module EP 04

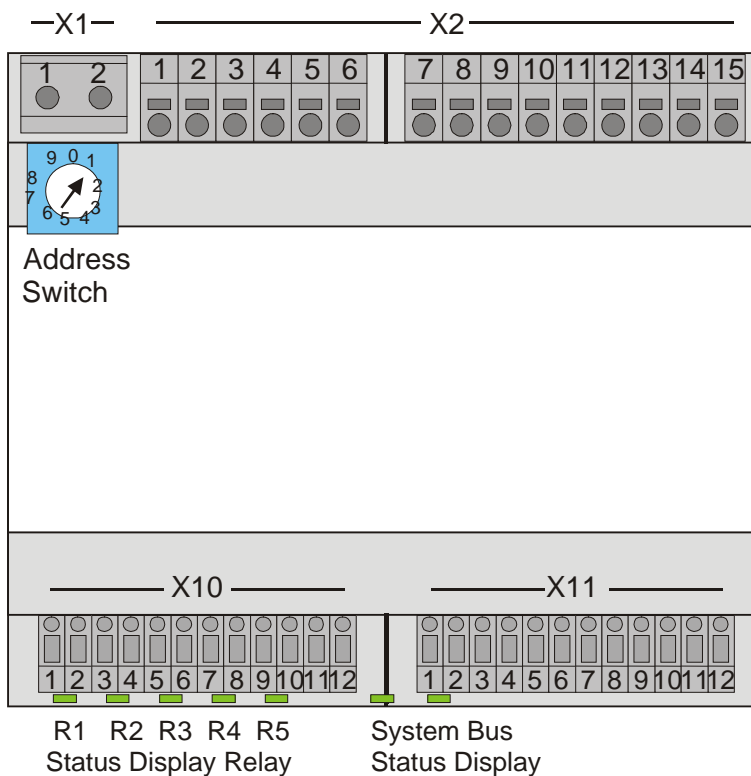

10 Notes and General Information

It is important to read this user manual carefully in order to understand the information and instructions. The CDA gas monitoring, control and alarm system may only be used for applications in accordance to the intended use. The appropriate operating and maintenance instructions and recommendations must be followed.

Due to permanent product developments, AP reserves the right to change specifications without notice.

The information contained herein is based on data considered to be accurate. However, no guarantee or warranty is expressed or implied concerning the accuracy of these data.

10.1 Intended Product Application

The CDA is designed and manufactured for controlling, for saving energy and keeping OSHA air quality in commercial buildings and manufacturing plants.

10.2 Installers' Responsibilities

It is the installer's responsibility to ensure that the CDA system is installed in compliance with all national and local regulations and OSHA requirements.

All installations shall be executed only by technicians familiar with proper installation techniques and with codes, standards and proper safety procedures for control installations and the latest edition of the National Electrical Code (ANSI/NFPA70). It is also essential to follow strictly all instructions as provided in the user manual.

10.3 Maintenance

We recommended checking the CDA system regularly.

Due to regular maintenance differences in efficiency can easily be corrected.

Re-calibration and part replacement in the field may be implemented by a qualified technician and with the appropriate tools.

Alternatively, the removable Gas Controller may be returned for services to Automatikprodukter.

10.4 Limited Warranty

AP warrants the CDA against defects in material or workmanship for a period of one (1) year beginning from the date of shipment.

Should any evidence of defects in material or workmanship occur during the warranty period, AP will repair or replace the product at their own discretion, without charge.

This warranty does not apply to units that have been altered, had attempted repair, or been subjected to abuse, accidental or otherwise.

The above warranty is in lieu of all other express warranties, obligations or liabilities.

This warranty applies only to the CDAsystem.

Automatikprodukter shall not be liable for any incidental or consequential damages arising out of or related to the use of the CDA.