



ATEX Chlorine 0-20ppm Gas Detector Zone 1 and 2

Cl2



Oct.10



Features

- Self diagnostic procedure
- Continuous monitoring
- Zero point tracking
- Watch dog switch
- Easy calibration (zero, span and 4-20mA adjustment)
- Reverse polarity protected
- Overload-proof
- 4-20mA proportional or three-step (0, 10 and 20mA)
- 1 or 3 relays output switching thresholds
- Open collector output switching thresholds
- Modbus RTU serial bus
- EEx-d protection for Zone 1 or Zone 2
- EEx-n protection for Zone 2

Technical Data

Gas	Chlorine Cl2
Detection principle	Electrochemical, diffusion
Measuring range	0-20ppm
Accuracy	+/- 5% of range or 10% of reading
Response time	t90 <15 sec.
Repeatability	+/- 5% of range
Warm-up time	300 sec.
Control Unit	Micropr.10bit resolution 1024 points
Digital Filter	Variable average on the sampled values
Visual indications	Flashing LED
LCD-display	4 digits; 5 status LED
Stabilisation time	120 sec.
Zero-point drift	Auto zero drift compensation
Mounting height	0,2 metres above floor
Output signal	4-20mA, load 200ohm or 0-10-20mA
Serial Interface	Baud/9600 at Modbus
Power supply	18-28Vdc, -20%...+15%
Power consumption	90mA (at 12Vdc), 130mA
Expected lifetime	2 years, normal operating environment
Humidity range	20-90% rH non-condensing
Operating range	-10 up to +50C
Protection Class	IP55 EEX-n IP65 EEX-d
Pressure range	800 to 1100mBar (80 to 110kPa)
Air Velocity	< 6m/sec.

Application

For detection of chlorine within a wide range of industrial and commercial applications like waterworks, sewage plants, swimming pools etc.

The calibration for types without LCD display is possible via the handheld calibration keypad CKD.

The types with LCD display have a non intrusive magnetic calibration feature for easy calibration without opening the instrument and declassifying the area.

The gas detector is available with EEx-d for Ex zone 1 and 2, or with EEx-n protection for Ex zone 2.

Ordering Codes

Zone 1 or Zone 2, EEx-d enclosure IP65

ATEX 113 O2	0-20ppm	4-20mA, 12-24Vdc, Modbus
ATEX 113 O2/D	0-20ppm	4-20mA, 12-24Vdc, Modbus, c/w display

Zone 2, EEx-n enclosure IP55

ATEX 341 Cl2	0-20ppm.	4-20mA, 12-24Vdc, Modbus
ATEX 341 Cl2/D	0-20ppm.	4-20mA, 12-24Vdc, Modbus, c/w display

MOD	Protocol for Modbus RTU
Cl2 Head ATEX	Replacement Head (2 years lifetime)
Gland	ATEX gland for Zone 1

REL1 O2	Relay card for 1 alarm level
REL3 O2	Relay card for 3 alarm levels
REL3 O2/50	Relay card for 3 alarm levels
OC O2	Open Collector for 2 alarm levels

CSW	Calibration software
IDI	RS-interface
CKD	Service tool pluggable
CAP	Calibration adapter

Physical characteristics

Enclosure	Metal
Enclosure colour	Blue
Dimensions WxHxD	200 x 105 x 90mm EEx-d 169 x 106 x 62mm EEx-n
Weight	EEx-d 1,4kg, EEx-n 0,8kg
Cable entry	1 x NPT 3/4"
Mounting	Wall mounting (sensor head downwards)
Wire connection	Screw terminal, min 0,25mm ² and max 2,5mm ²
Wire length	Max.working resistance 200ohm (= wire resistance + controller input resistance)
Guidelines	EN50014, EN50018, EN50021 EN61779-1/4 (Performances)
ATEX Marking	CE 722 II 2G EEXd IIC T6 CE 722 II 3G EEx nA IIC T6
EC Type Certification	CESI01ATEX053 EEX-d CESI03ATEX339 EEx-n
Sensor Head	CESI01ATEX013U CESI01ATEX066U
One-relay output	Max 24Vac/dc, 100mA@12Vdc 50mA@24Vdc
Three-relay output	Max 24Vac/dc, 1A
Two open collector O/P	Max 24Vdc, 20mA

Relay Package

The **1 relay** card for the ATEX gas detectors allows the detector to be provided with 1 voltage free changeover contact.

Mounting

Before inserting the **REL1 O2** card be sure the detector has been powered off.

Insert the vertical plug-in card into the 10-pole connector, paying attention to leave the two left side poles free.

Make sure the card has been fully plugged in.

Turn the side comprising the red LED towards the main terminal board, as shown in the drawing here below..

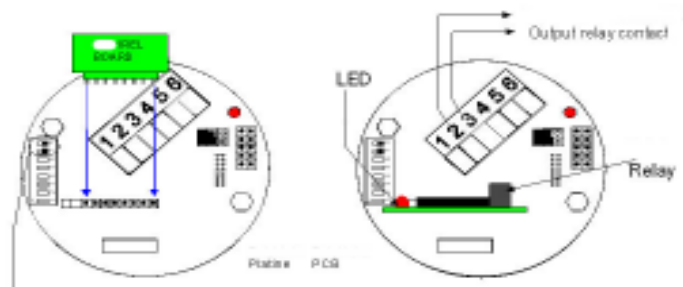
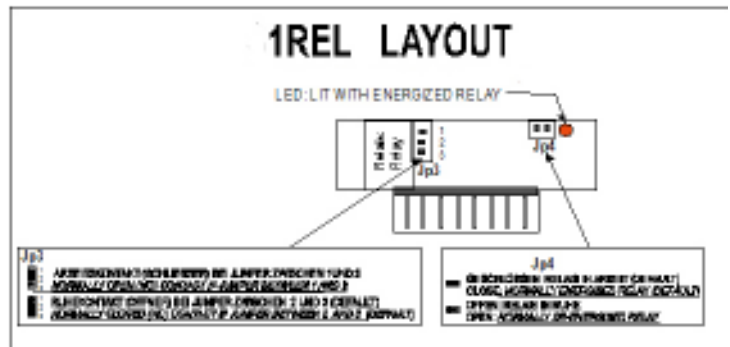

Connecting Diagram

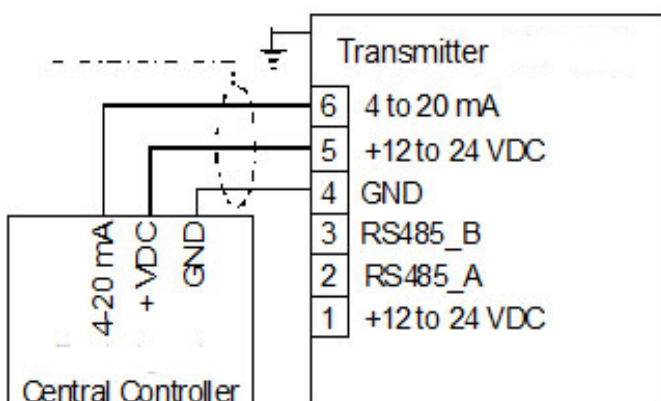

Relay Package 3 relays

The three-relay card for ATEX gas detectors allows the detector to be provided with tension free changeover contacts.

- The first output is to be associated to the *Fault* and *Watch-dog alarm*
- The second output can be associated to the first or second alarm threshold
- The third output can be associated to the second or third alarm threshold.

The card comes complete with a flat cable and connector to be easily plugged on the detector's mother board.

Contacts Rating: 24 VDC-1 A

Operation Voltage:

from 10.2 to 16 VDC and from 19 to 28 VDC

**Only one model of REL3 O2 is available:
before connecting the relay card, please make sure
the detector's operation voltage is within the values
here above.**

Mounting

Verify the detector has been disconnected before mounting the **REL3 O2**.

Insert the supports into the holes on the PCB, as per the drawing on page 2.

Insert the female connector at the edge of the flat cable into the male connector J7 on the PCB.

Beware that the black triangle on the female connector (corresponding to pin one) is facing towards the internal part of the PCB.

Tighten the card to the supports with the screws the relay-card kit is equipped with.

Once the card has been properly mounted the terminal block shall be faced towards the lower part of the detector, i.e. towards the sensor head.

The detector can now be wired, connected and powered on.

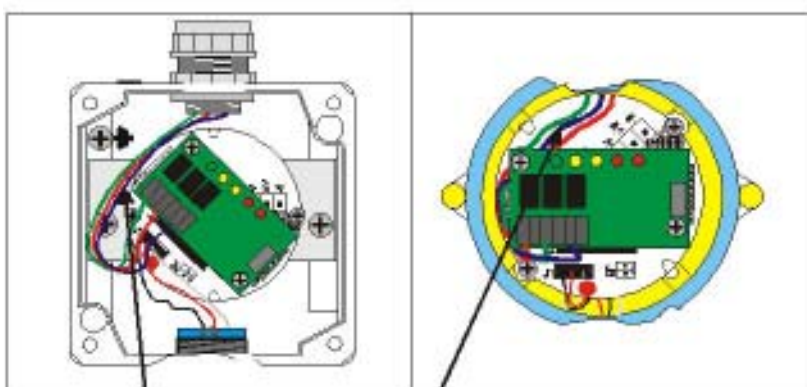
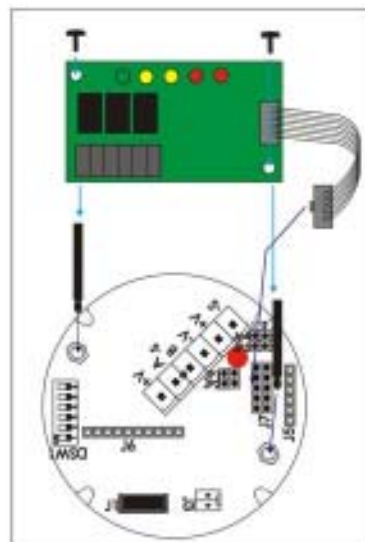

3REL LAYOUT

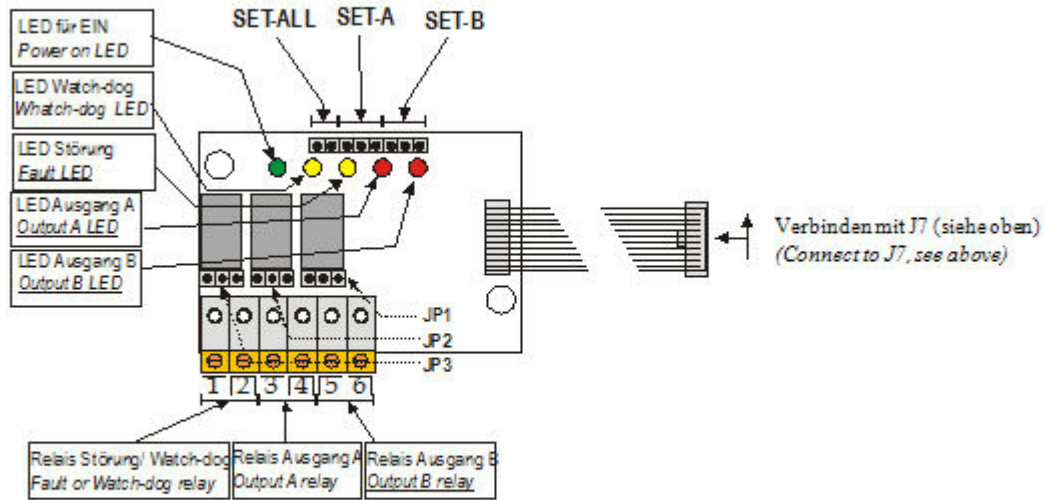

SET-ALL

- OFFEN: RELAIS ARBEITSSTROMPRINZIP (DEFAULT)
OPEN: NORMALLY ENERGISED RELAY (DEFAULT)
- GESCHLOSSEN: RELAIS RUHESTROMPRINZIP
CLOSE: NORMALLY DE-ENERGISED RELAY

SET-A

- RELAIS 'A' VERBUNDEN MIT ALARMSCHW. 1 (DEFAULT)
RELAY 'A' COUPLED TO THRESHOLD 1 (DEFAULT)
- RELAIS 'A' VERBUNDEN MIT ALARMSCHWELLE 2
RELAY 'A' COUPLED TO THRESHOLD 2

SET-B

- RELAIS 'B' VERBUNDEN MIT ALARMSCHWELLE 2 (DEFAULT)
RELAY 'B' COUPLED TO THRESHOLD 2 (DEFAULT)
- RELAIS 'B' VERBUNDEN MIT ALARMSCHWELLE 3
RELAY 'B' COUPLED TO THRESHOLD 3

JP3

- SCHLIESSER/ARBEITSKONTAKT ZWISCHEN KLEMME 1 UND 2 STÖRUNG/WATCH-DOG (DEFAULT)
NORMALLY OPEN (NO) CONTACT BETWEEN TERMINAL 1 AND 2 FAULT/WATCH-DOG (DEFAULT)
- ÖFFNER/RUHEKONTAKT ZWISCHEN KLEMME 1 UND 2 STÖRUNG/WATCH-DOG
NORMALLY CLOSED (NC) CONTACT BETWEEN TERMINAL 1 AND 2 FAULT/WATCH-DOG

JP2

- SCHLIESSER/ARBEITSKONTAKT ZWISCHEN KLEMME 3 UND 4 VON RELAIS A (DEFAULT)
NORMALLY OPEN (NO) CONTACT BETWEEN TERMINAL 3 AND 4 RELAY A (DEFAULT)
- ÖFFNER/RUHEKONTAKT ZWISCHEN KLEMME 3 UND 4 VON RELAIS A
NORMALLY CLOSED (NC) CONTACT BETWEEN TERMINAL 3 AND 4 RELAY A

JP1

- SCHLIESSER/ARBEITSKONTAKT ZWISCHEN KLEMME 5 UND 6 VON RELAIS B (DEFAULT)
NORMALLY OPEN (NO) CONTACT BETWEEN TERMINAL 5 AND 6 RELAY B (DEFAULT)
- ÖFFNER/RUHEKONTAKT ZWISCHEN KLEMME 5 UND 6 VON RELAIS B
NORMALLY CLOSED (NC) CONTACT BETWEEN TERMINAL 5 AND 6 RELAY B

* HINWEIS : ALLE ANGABEN ÜBER DIE RELAISKONTAKTE BEZIEHEN SICH AUF DIE NICHT ANGESCHLOSSENE KARTE!
NOTE : ALL INDICATIONS GIVEN ON RELAY CONTACTS ARE MEANT FOR NON-CONNECTED CARD!

Introduction

The 2-open collector card for gas detectors provides the detector with 2 independent outputs with negative reference.

According to the JP jumper position on the O.C. board, one of the following statuses may be chosen:

- JP open O.C. normally closed
- JP closed the O.C. normally open

Technical Specification

O.C. Rating Max 20 mA

Installation

Before inserting the O.C. card, make sure the detector has been disconnected.

Insert the vertical plug-in card into the 10-pole connector, paying attention to leave the two left side poles free.

Make sure the card has been fully plugged in.

The red LEDs on board should face the general terminal block, as shown in the drawing here below.

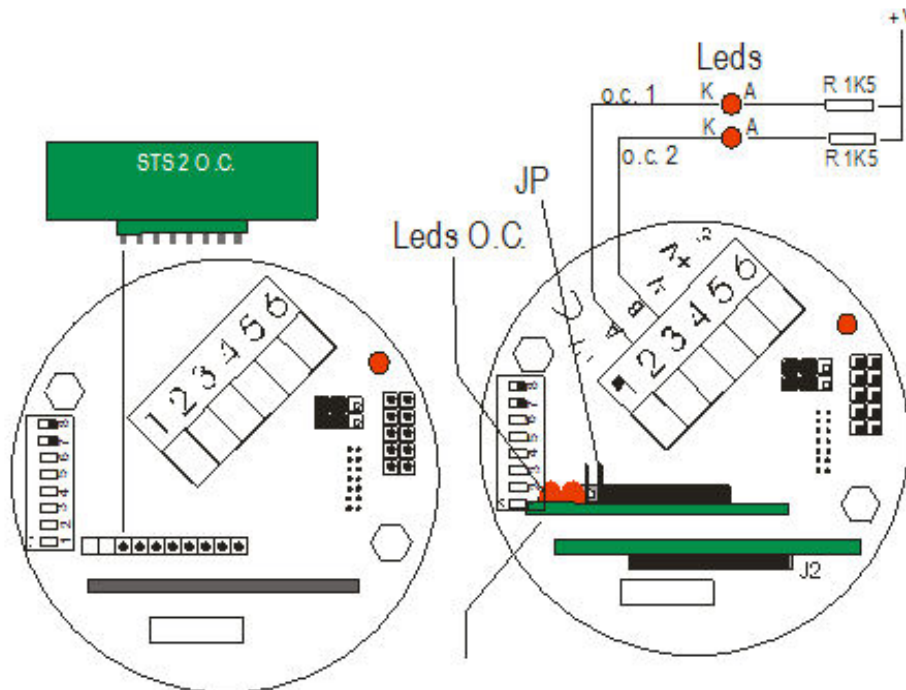

dip 7	dip 8	(A) o.c.1	(B) o.c.2
OFF	OFF	FLT	WD AL1
OFF	ON	FLT AL3	WD AL2
ON	OFF	FLT AL2	WD AL1
ON	ON	FLT AL3	WD AL1

Default configuration

Dip 7 ON - Dip 8 ON- JP Closed