

CE RAR8

### Technical Data

<b>Power Supply</b>	24Vac/dc +/-10% 50-60Hz 230Vac +/-10% 50-60Hz
<b>Power Consumption</b>	
Operating	7W      8W(aux-version)
At the end stops	2W      5,5W(aux-version)
<b>Torque</b>	8Nm
<b>Protection Class</b>	IP54 and II
<b>Auxiliary Switch Rating</b>	3A(1,5A)@250Vac Switching point Adjustable 40...90°(b) Fixed at 5° (a)
<b>Angle Limiting</b>	Mechanical end stops
<b>Direction of Rotation</b>	Bidirectional (right/left)
<b>Angle of Rotation</b>	-5...+90°(mechanical)
<b>Shaft Dimension Dia</b>	8-21mm round / 6-15mm square 40mm minimum shaft length
<b>Running Time</b>	70sec <25sec of spring back
<b>Noise Level</b>	Below 45dB (A)
<b>Usage Life</b>	Min. 60'000 open-close operations
<b>Position Indication</b>	Mechanical
<b>Control Signal</b>	2-point
<b>Ambient Temperature:</b>	-20...+ 50°C
<b>Ambient Humidity:</b>	5...95%rH non-condensing
<b>Weight</b>	2,2 resp 2,3kg (aux-version)
<b>Maintenance</b>	Maintenance free
<b>Standards</b>	The actuators meet CE requirements

### Features

- 8Nm torque to regulate dampers up to appr. 1,5m2
- Auxiliary potential-free switches, fixed and adjustable
- Manual override by crank handle
- Anti-rotation bracket provided for stability
- Adjustable angle of rotation, mechanical endstops
- Simple direct mounting by universal adapter
- Available with 1 m cable connection
- Energy savings at end stops

### Short Description

By using the mounting clamp the actuators can be direct couple mounted over the damper shaft

The compact size allows for easy installation where space is limited.

### Damper Size

When calculating the torque required to operate dampers, it is essential to take into account all the data supplied by the damper manufacturer concerning cross sectional area, design, mounting and air flow conditions.

The recommended damper size are guide values

### High dependable performance

RAR8 on/off type damper actuator is a high quality spring return damper actuators designed for use air dampers, butterfly valve, ball and seat valve with the use of special adapter.

The actuator opens the damper loading the return-spring: with is current cut-off the spring moves the damper in a safe position.

The actuator can be controlled by a suitable handle.

By this way the spring can be loaded and the actuator can be positioned as required.

### Ordering

<b>RAR8 24D</b>	Fail Safe Actuator	8Nm	24Vac/dc
<b>RAR8 230D</b>	Fail Safe Actuator	8Nm	230Vac
<b>RAR8 24DS2</b>	Fail Safe Actuator	8Nm	24Vac/dc aux.sw.
<b>RAR8 230DS2</b>	Fail Safe Actuator	8Nm	230Vac aux.sw

### Wiring diagram

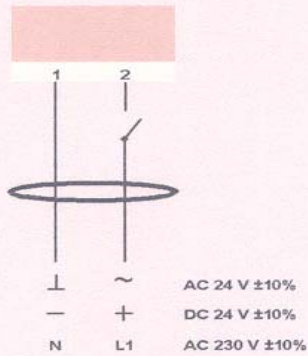

S1 ON 0° → 90°  
 OFF 0° → 90°

### Changing direction of rotation

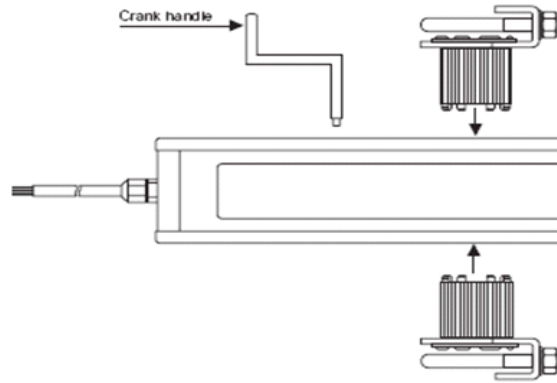

⚠ 24VAC/DC: Connect via safety isolating transformer.  
 230 VAC: To isolate from the main power supply, the system must incorporate a device which disconnects the phase conductors (with at least a 3 mm contact gap).

### Auxiliary switches (S)

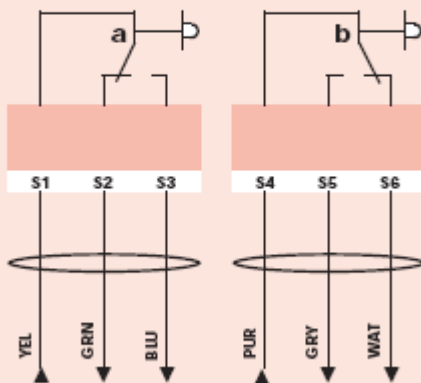

### Auxiliary switch adjustment Switch a Factory set at 5°

Switch b adjustable 40°...90°

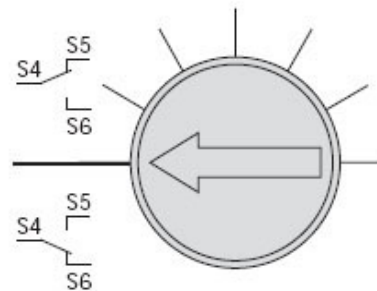

Built-in Microswitch Adjustment  
 Move the screw of the microswitch.

### Electrical Wiring

YEL - yellow  
 GRN - green  
 BLU - blue  
 PUR - purple  
 GRY - grey  
 WAT - ochre  
 BLK - black  
 RED - red

### Angle-of-rotation limiting

Mechanical Limited Adjustment

1. Loosen screw of the mechanical limited.
2. Move the limited to the appropriate position.
3. Tighten on the screw.

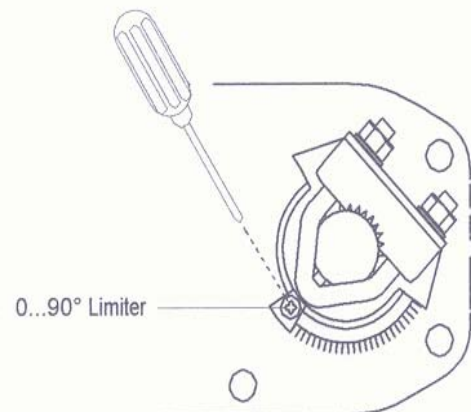



# Fail Safe Actuator On/Off Spring Return

8Nm

RAR 8

Jan.10

