



- No spring return
- Running time 150 sec
- 10 Nm
- Modulating 2 ... 10 Vcc ??
- Power supply 230V ac, 24V ac, 24V dc
- According to EN 60079-0, EN60079-1,
- EN 60079-31
- Zones 1, 2, 21, 22



NEMKO 03 ATEX 1242X

II 2G Ex d IIC T6 Gb

II 2D Ex tb IIIC T67 °C

For zone 1, 2, 21, 22

Applications

The EXNM actuators are intended for the operation of air control damper in ventilation and air conditioning system up to approx 2m².

The product may differ from the illustration

Features:

Just powered, the actuator moves the damper to its start position, then it moves to the position set by the control signal.

If the control signal is interrupted the motor locks the damper position.

The actuator is overload protected. The actuator can be mounted directly on the damper shaft if square, 12 x 12 mm or 10 x 10 mm (adaptor included); Several mounting brackets are available for applications where the actuator cannot be directly coupled to the damper shaft.

The cable glands are fit for cable diameters from 8 to 10,5 mm.

Product range

ITEM	Auxiliary Switch
EXNM 0 B SR2 0 S 000	None

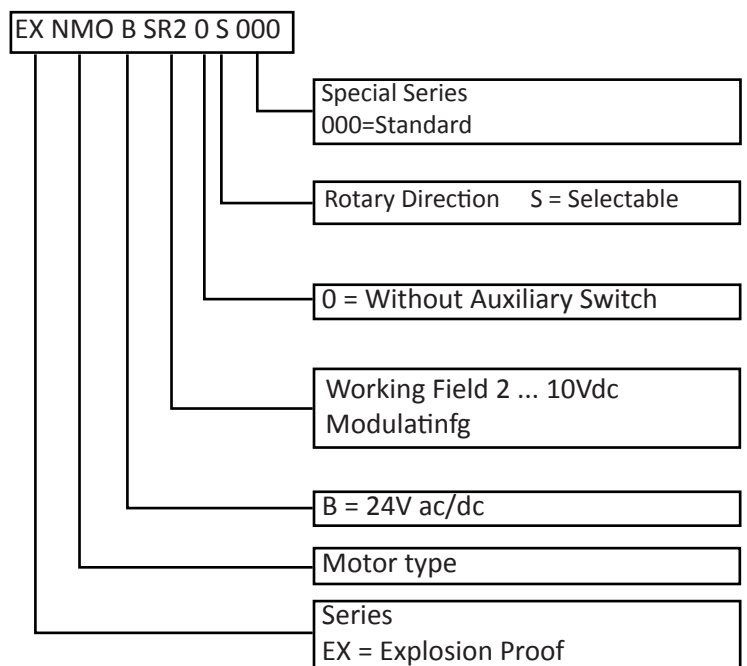

Options available on request:

- Different angle of rotation
- Different wiring length

Technical data

Torque	20 Nm
Control Mode	dc 0 ... 10V
Working Field	dc 2 ... 10V
Feedback	sdc 2 ... 10V
Angle of rotation	95°
Running time	150 Sec.
Ambient temperature	-20°C + 50°C
Degree of protection	IP66
Housing material	Aluminium baked varnish
Maintenance	None
Fastening	Terminal block in Ex e box (optional)
Wiring length	1m cable
Weight	4.0 Kg
Auxiliary switches	6A (3A) max 250V switching point 5° e 85°
EMC	CE according to 2004/108/EC
Low voltage directive	CE according to 2006/95/EEC
Halogen – Free wiring	According to IEC 60332-1/3 and According to IEC 60754-1/2

NOTE:

- Read the note about the use and torque requirements of the damper manufacturer
- All electrical wirings must be according to local standards.
- Electrical connections by power off only.
- Ex e junction box must not be opened under any circumstances when the power is on.
- Actuator cable must be installed in a fixed position and protected against damage.
- Avoid excessive vibrations.
- Before switching-on, check that no other equipment is damaged and make sure that supply voltage corresponds with the Actuator's specification.
- Before switching-off check for possible effects on other equipments.
- The Actuator cannot and is not to be opened to guarantee explosion proof and warranty.
- For any problem contact Automatikproduktur.
- The equipment shall be marked "X" since flameproof joint is other than the relevant minimum or maximum according to CEI EN 60079-1. Information on dimension of flameproof joints available at Automatikproduktur.

Power supply	24 Vac ± 20% 50/60 Hz
	24 Vdc ± 20%
Power consump.: running	2.0 W
Power consump.: At rest	0.4 W
Sizing	4.0 VA

Electrical diagram

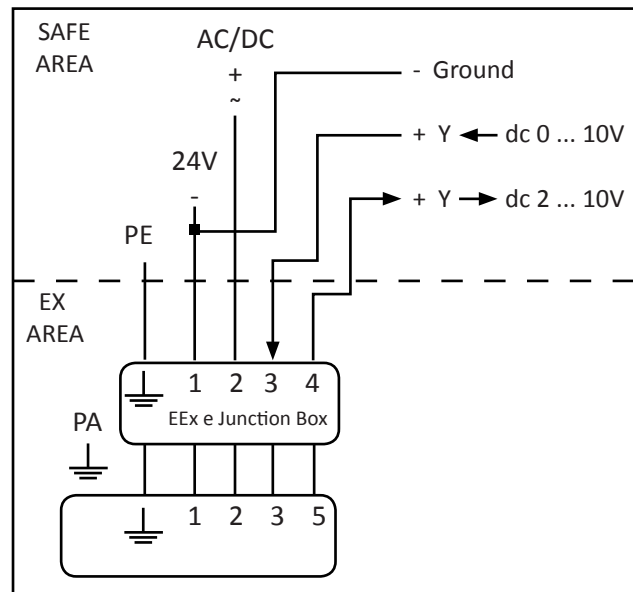

- In order to change the rotary direction it is necessary to:
- Unscrew cap indicated by the arrow
 - Rotate the switch as per drawing
 - Carefully screw cap exerting a slight pressure at the end of the rotation.

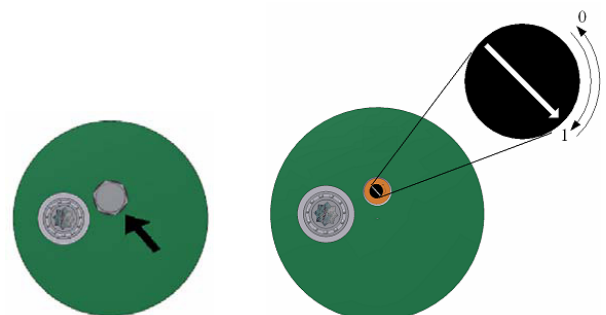

ATTENTION:

The above instructions must be carefully and strictly followed.
Automatikproduktur disclaims any liability whatsoever for any loss caused by not following of the above instructions.

Rotary Direction "R". For Damper normally closed N.C.

MOTOR
 Power: ON
 Power on WIRE 2
 Control: 2 .. 10 V

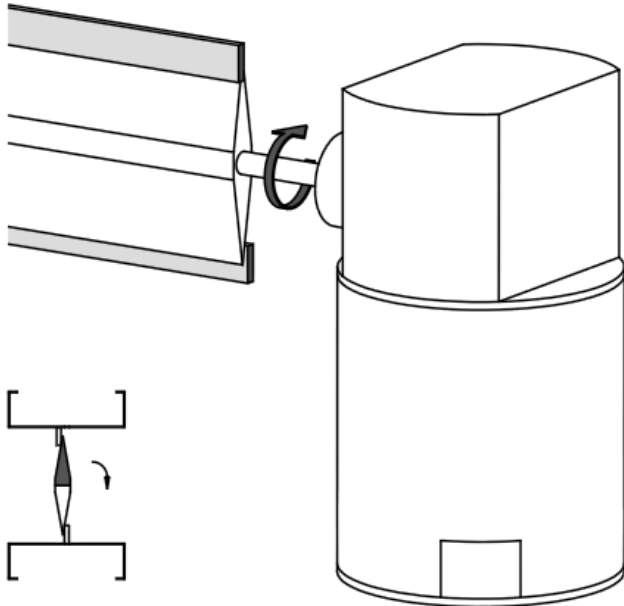

MOTOR or SPRING RETURN
 Power: OFF
 Power on WIRE 3
 Control: 10 .. 2 V

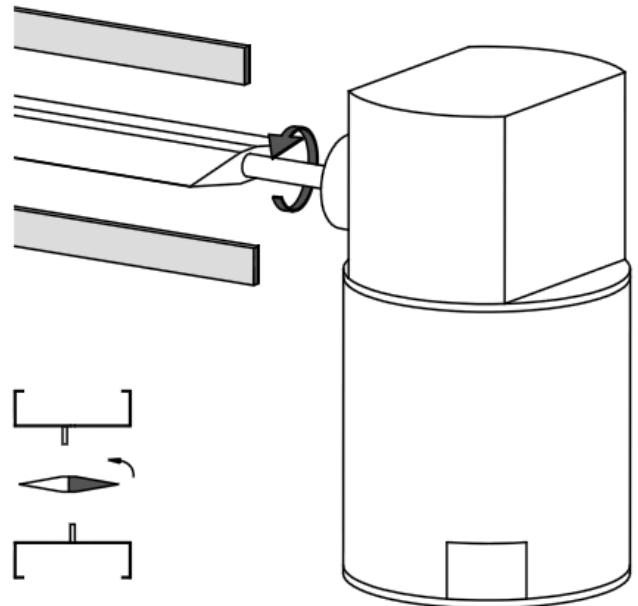

Rotary Direction "L". For Damper normally closed N.C.

MOTOR
 Power: ON
 Power on WIRE 2
 Control: 2 .. 10 V

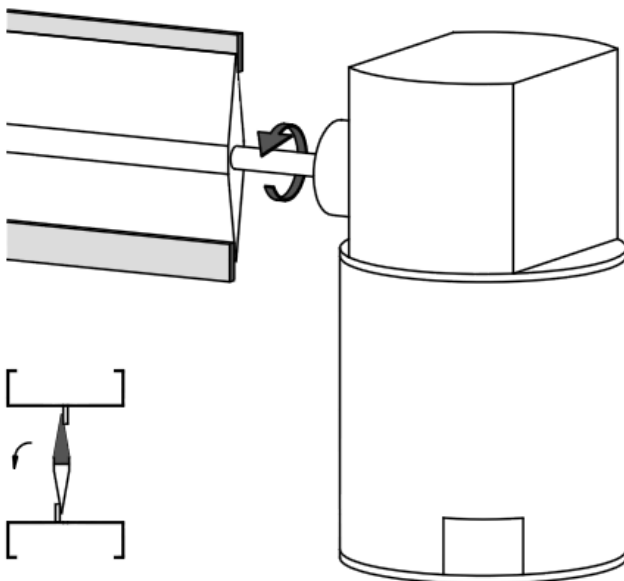

MOTOR or SPRING RETURN
 Power: OFF
 Power on WIRE 3
 Control: 10 .. 2 V

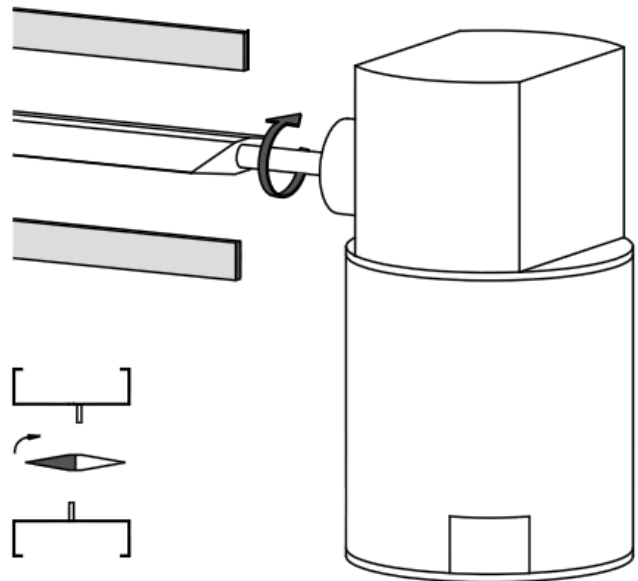

Subject to technical changes without notice. Rev. 00



Rotary Direction "R". For Damper normally open N.O.

MOTOR
Power: ON
Power on WIRE 2
Control: 2 .. 10 V

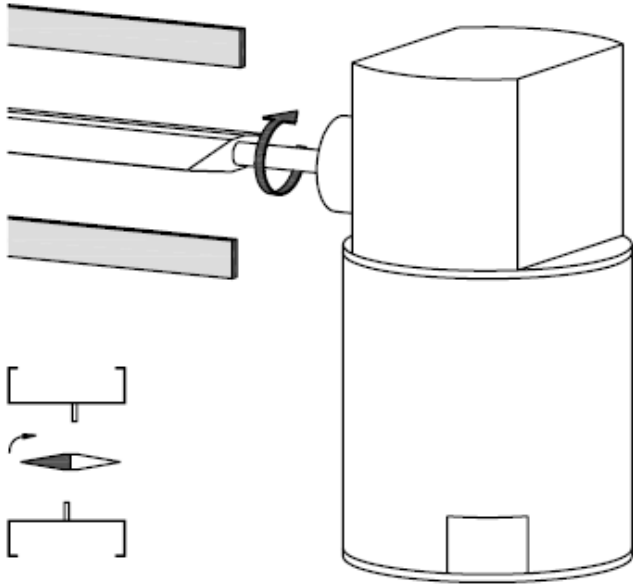

MOTOR or SPRING RETURN
Power: OFF
Power on WIRE 3
Control: 10 .. 2 V

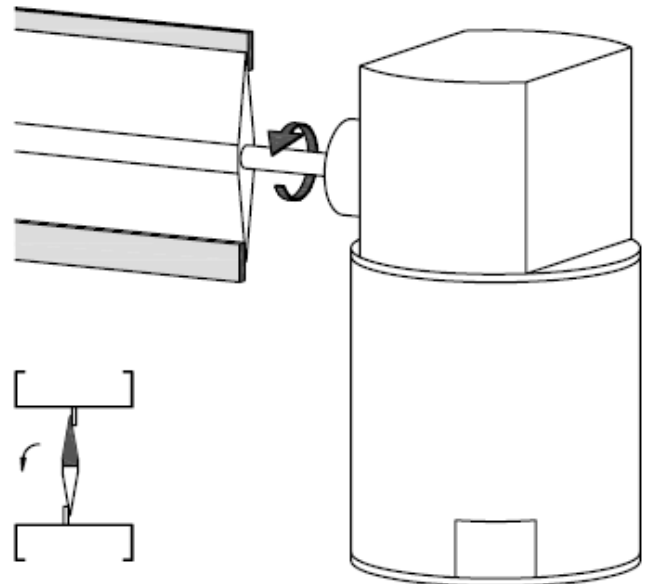

Rotary Direction "L". For Damper normally closed N.O.

MOTOR
Power: ON
Power on WIRE 2
Control: 2 .. 10 V

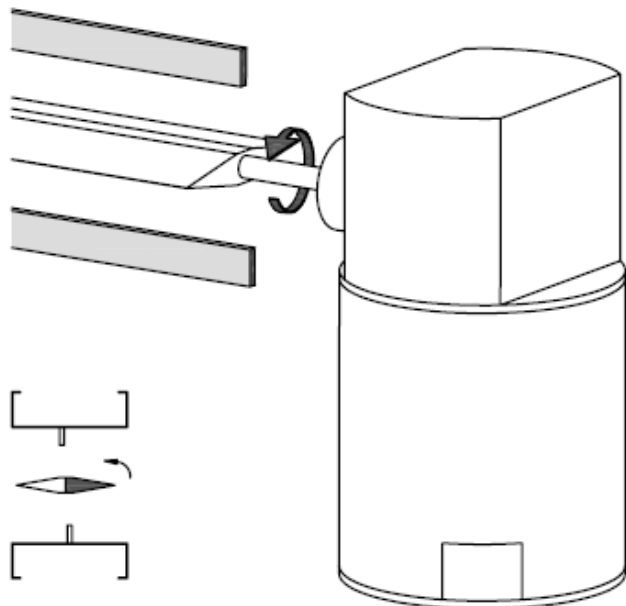

MOTOR or SPRING RETURN
Power: OFF
Power on WIRE 3
Control: 10 .. 2 V

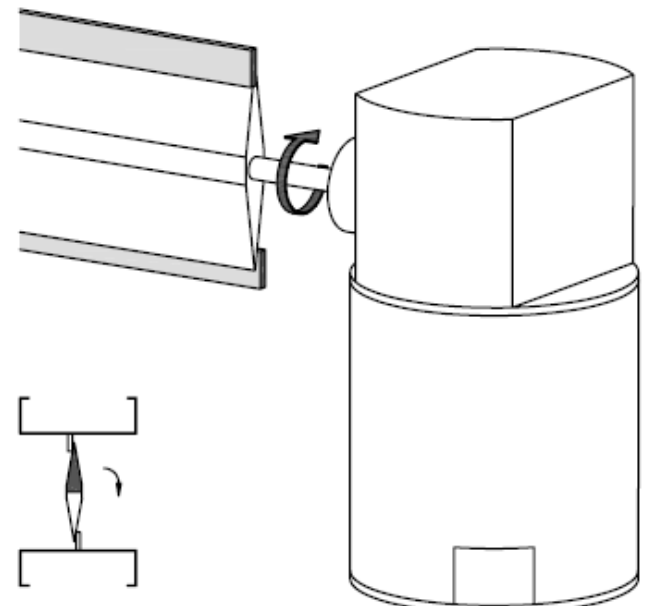

Subject to technical changes without notice. Rev. 00

Dimensions and Mounting Instructions
EXAF - EXBF - EXBE - EXBG - EXSM - EXAM

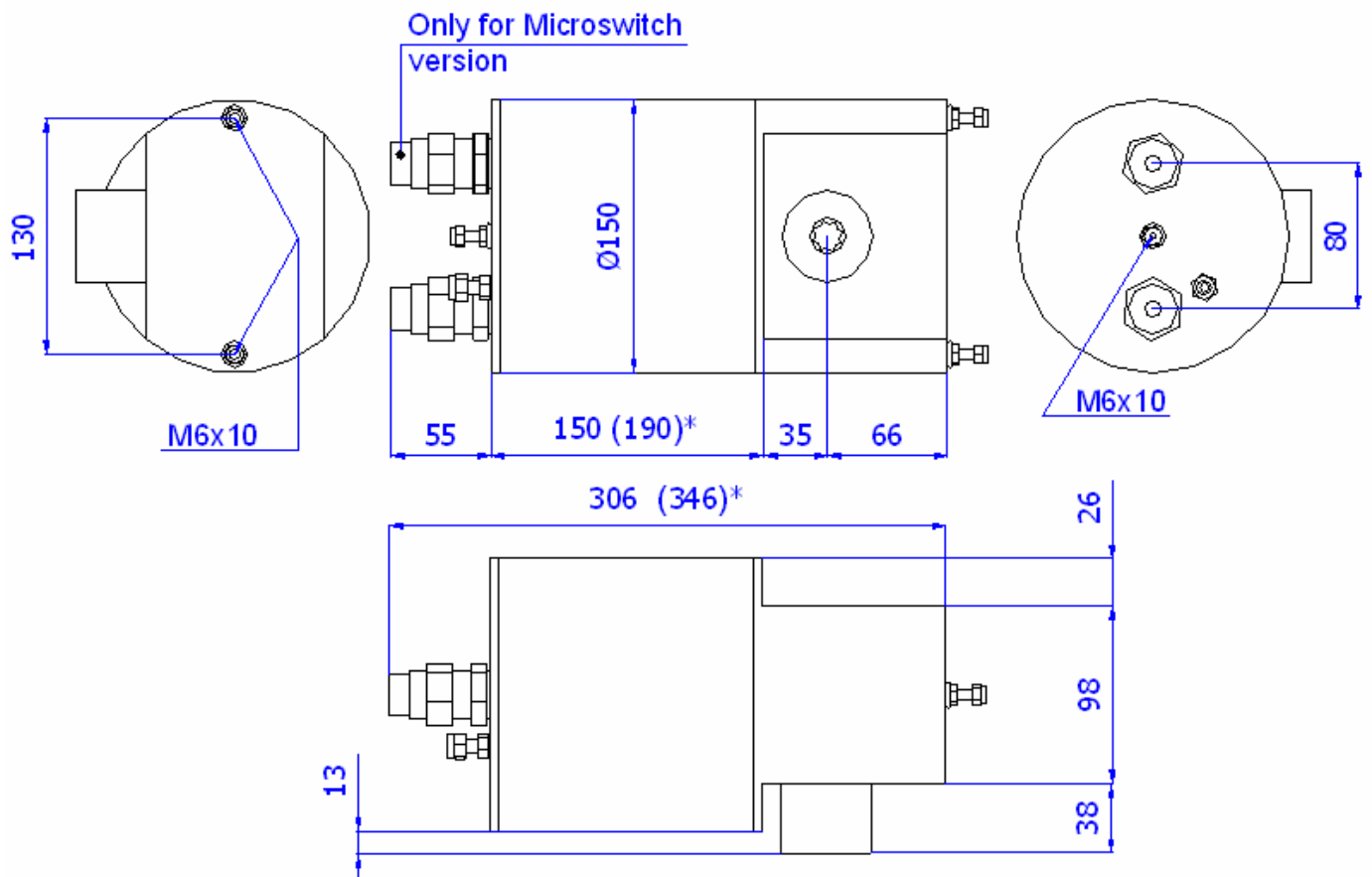

*= Only series EXAF, EXBF, EXBG, EXBE

Note: Dimensions are specified in millimeters

EXNM

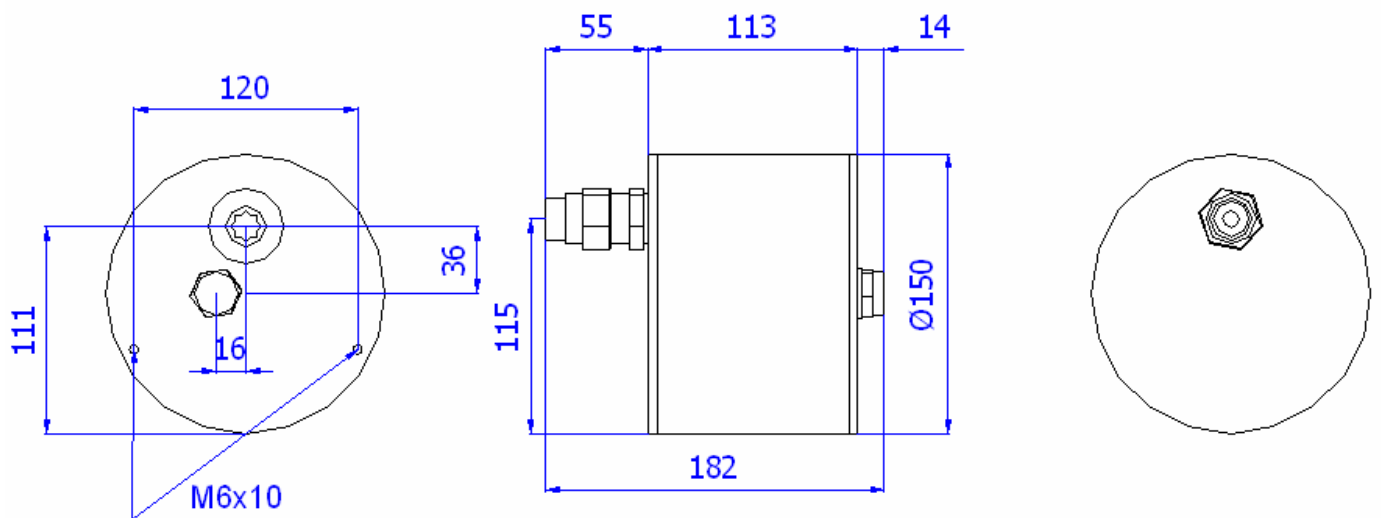

Note: Dimensions are specified in millimeters

Dimensions and Mounting Instructions
EXAF - EXBF - EXBE - EXBG - EXSM - EXAM

EXNM

