



Actuator Specification & Installation Instructions



Feature:

- Up to 4000 in.lb [450Nm].
- Clutch for manual adjustments.
- Maintenance free.
- Control signal fully programmable.
- Fail safe (battery backup) (on model 010 & 030).
- Auxiliary switches (on model 020 & 030).
- IP56 enclosure.

UM000
UM020
UM010
UM030
WM000
WM020
WM010
WM030

Technical Data	UM000	UM020	UM010	UM030	WM000	WM020	WM010	WM030
Auxiliary switches	No	Yes (2)	No	Yes (2)	No	Yes (2)	No	Yes (2)
Fail safe	No		Yes		No		Yes	
Torque	2500 in.lb. [280 Nm] at rated voltage				4000 in.lb. [450 Nm] at rated voltage			
Running time through 90°	4 min.				8 min.			
Feedback	4 to 20 mA or 2 to 10 VDC adjustable							
Power consumption	40 VA							
Power supply	22 to 26 VAC or 28 to 32 VDC							
Electrical connection	18 AWG [0.8 mm ²] minimum							
Inlet bushing	3 inlet bushing of 7/8 in [22.2 mm]							
Control signal	Analog or Digital or PWM programmable (factory set with Analog control signal)							
Angle of rotation	0 to 110 degrees, electronically adjustable (factory set with 110° stroke)							
Direction of rotation	Reversible, Clockwise (CW) or Counterclockwise (CCW) (factory set with CW direction)							
Ambient temperature	0°F to +122°F [-18° C to +50° C]							
Storage temperature	-22°F to +122°F [-30° C to +50° C]							
Relative Humidity	5 to 95 % non condensing.							
Weight	26 lbs. [12 kg]							

Warning: Do not press the clutch when actuator is powered

Dimensions

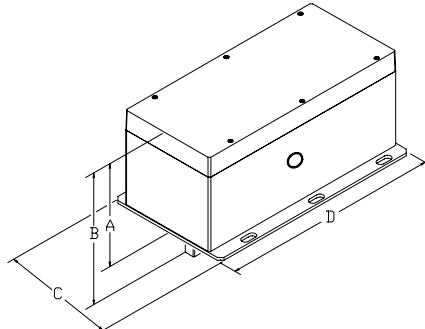

Dimension	Inches	Metric (mm)
A	6.75	169.4
B	7.95	201.9
C	7.85	199.4
D	14.45	367.0

Caution

We strongly recommend that all neptronic® products be wired to a separate transformer and that transformer shall service only neptronic® products. This precaution will prevent interference with, and/or possible damage to incompatible equipment.
When multiple actuators are wired on a single transformer, polarity must be observed. Long wiring runs create voltage drop which may affect the actuator performance.

Exploded view

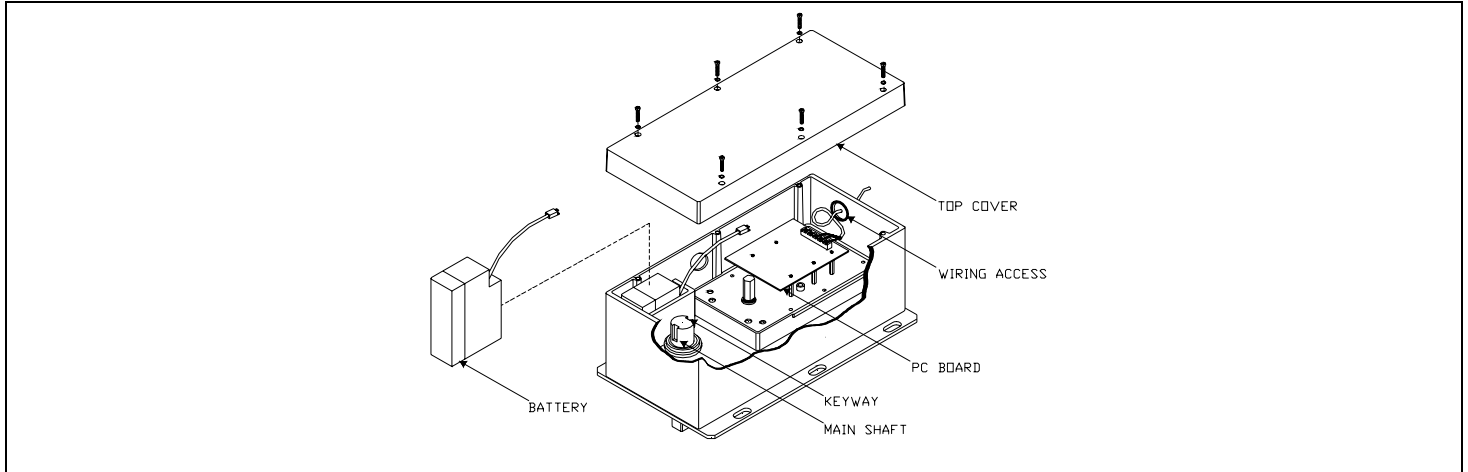

Wiring Diagrams

Analog or PWM

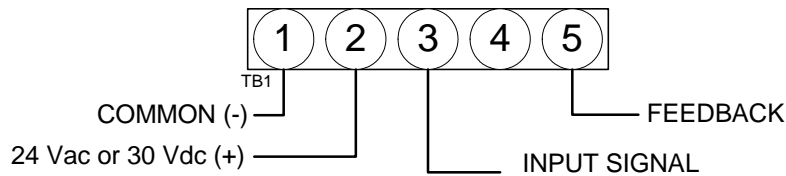

Digital signal

Digital - 3 wire / 2 position

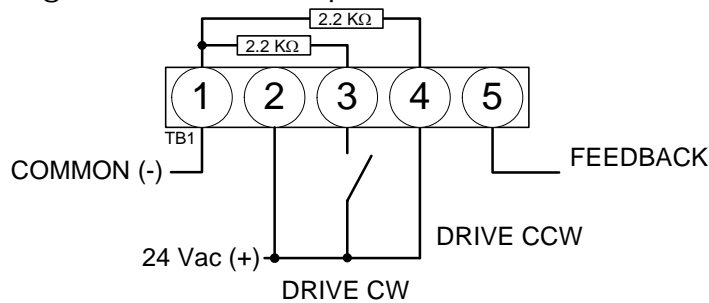

Digital - 4 wire / 3 point floating

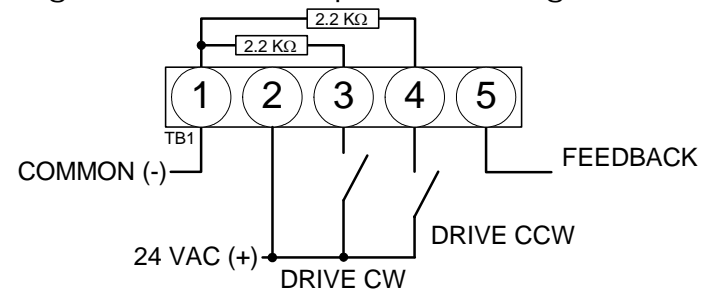

Special consideration for Digital control

In this mode, the actuator is sensitive to induced electrical voltages **from external sources**. To prevent such interference, if the signal on pins 4 and 3 on TB1 are from an **external 24 Vac source**, install a resistor 2.2kohm, 0.5W between pins 4 and 1 and another of 2.2kohms, 0.5W between pins 3 and 1 of TB1. These resistors are included.

Input Signal and Feedback setup

	Input Signal	Feedback
Analog Mode	Input Signal is set with Dipswitch # 3 DS1-3 at OFF = 2 – 10Vdc (default setting) DS1-3 at ON = 4 – 20mA	Feedback is set with Dipswitch #4 DS1-4 at OFF = 4 – 20mA (default setting) DS1-4 at ON = 2 – 10Vdc
Digital & PWM Mode	No Input Signal Setting  DS1-3 MUST be at OFF	

PC Board

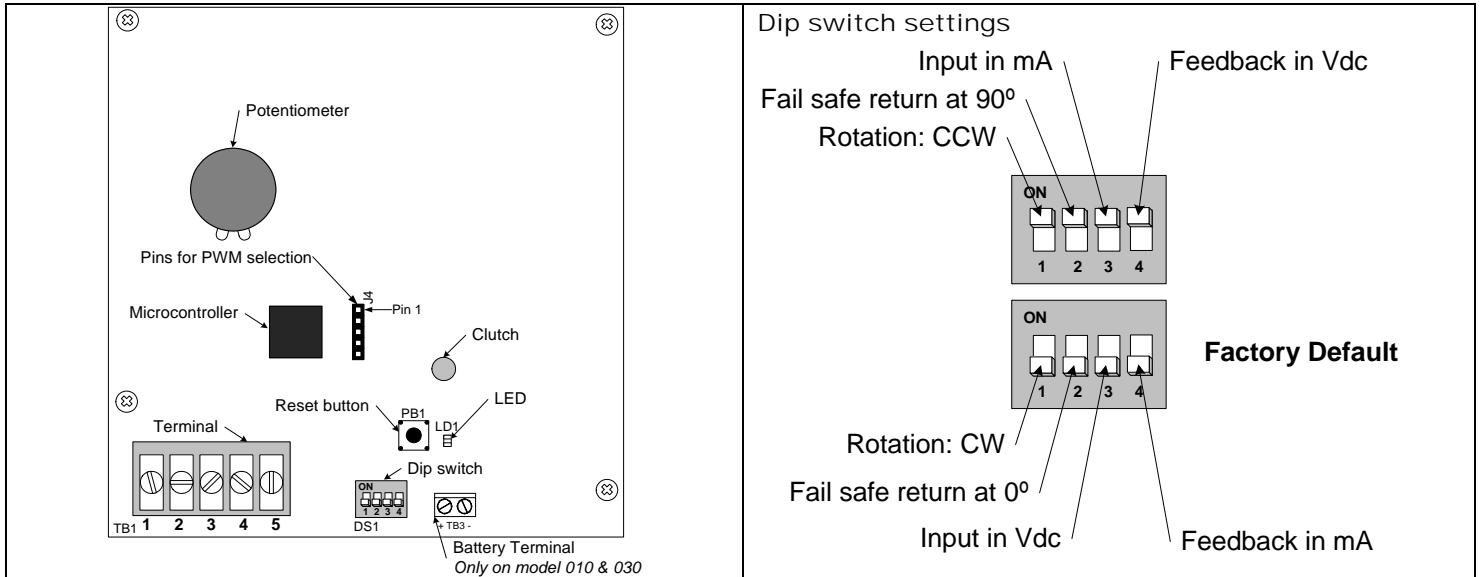

Stroke adjustment – No control signal change

1. Apply power and, **wait for at least 10 seconds**.
2. Press and release the reset button to start the auto-stroke process. The LED should be illuminated.
 - First option: The actuator will then travel in both directions to find its limit and position itself according to the demand. The LED will extinguish, the process is complete.
 - Second option: When the desired end position is reached, press and release the reset button. The actuator will now return back to its original position. (you can also press and release the reset button when it reaches the original position) The LED will extinguish, the process is complete.

Programming – Change of control signal & PWM pulse setting

1. Remove power and put all dip switches "OFF" (factory preset).
 2. Apply power and, **within 10 seconds**, press and release the reset button. The LED should be blinking.
 3. Select the control signal with dip switches:
- | | Digital or Analog Modes | PWM Mode |
|---|---|-------------------------------|
| Move switch No1 "ON" and then "OFF". | Digital (On/Off or 3 point floating) | 5 sec. pulse (factory preset) |
| Move switch No2 "ON" and then "OFF". | Analog (Default) | 25 sec. pulse |
- Stroke adjustment
see the stroke adjustment section above.

Enabling or disabling PWM mode

1. Remove power supply to actuator
 2. Install jumper between pin 3 & 4 of J4
 3. Select the desired action using the dipswitches (DS1):
- | DS1-1 | DS1-2 | Action |
|-------|-------|------------------|
| OFF | ON | Enable PWM Mode |
| ON | OFF | Disable PWM Mode |
4. Re-apply power supply to actuator
 5. **Wait 5 seconds**
 6. Remove power supply to actuator
 7. Remove jumper between pin 3 & 4 of J4, re-install it between pin 4 & 5.
 8. Re-apply power supply to actuator
PWM is factory preset at 5 sec. pulse, refer to programming section above to change pulse setting.
-
- When not used for programming, jumper is placed between pin 4 & 5

Zero and span calibration

This feature is applicable to analog control signal only.

1. Remove power and put all dip switches "OFF". (factory preset).
2. Apply power and, **within 10 seconds** press and hold the reset button until the LED blinks once. The Zero and span calibration process then start.
3. Release the reset button. The LED is now constantly illuminated.
4. Apply new minimum voltage.
It can be any value between 0 to 7 VDC, with an external 0 to 10 volt supply (ex: MEP).
5. Press and release the reset button to memorize the new minimum voltage. The LED blinks once.
6. Apply new maximum voltage.
It can be any value between 3 to 10 VDC, this value should be greater than the new minimum value.
7. Press and release the reset button to memorize the new maximum voltage. The LED blinks once. The Zero and span calibration process is complete.

Note: To reset zero and span to 2 to 10 VDC (factory value). You just have to re-select the analog control signal mode, see Programming.

Wiring Diagrams for auxiliary switches (on model 020 & 030)

